



WALTHER

WALTHER LGV

The Sound of Silence.



AIR RIFLE · LUFTGEWEHR · CARABINE À AIR COMPRIMÉ · CARABINA DE AIRE COMPRIMIDO
FUCILE AD ARIAN COMPRESSA · ПНЕВМАТИЧЕСКАЯ ВИНТОВКА · BROŃ PNEUMATYCZNA · HAVALI TÜFEK
cal. 4,5 mm (.177)
cal. 5,5 mm (.22)

EN Operating instructions 2 - 11 | DE Bedienungsanleitung 12 - 22 | FR Mode d'emploi 23 - 33 | ES Instrucciones de uso 34 - 44
IT Istruzioni per l'uso 45 - 55 | RU Инструкция по эксплуатации 56 - 66 | PL Instrukcja obsługi 67 - 77 | TR Kullanım Kılavuzu 78 - 88

[V]

VIBRATION
REDUCTION
SYSTEM

[S]

SUPER
SILENT
TECHNOLOGY



Best Performance – WALTHER air rifles for sporting and recreation.

The name Walther is synonymous with the development of innovative air rifles. Competitors throughout the world, including Olympic and international champions, put their trust in the technical perfection of these sporting arms. The same is true for members of gun clubs and recreational shooters. Carl Walther is today a leading manufacturer of air rifles for sporting and recreation.

The success story began in the 1950s and 1960s, when air rifle shooting started to gain wide popularity. The LG51, the first spring-piston rifle developed by Walther, played a major part in this. The Master air rifle LG55 M was used by the gold-medal-winning Swiss team at the 1966 world championships. And in 1964 Walther brought out a rifle with enhanced precision: the Walther LGV.





SAFE HANDLING OF GUNS

EN



DESCRIPTION OF PARTS



OPERATION



CARE



SAFETY INSTRUCTIONS

Learn how to handle your gun in a safe and proper manner. Remember that according to the basic rules of safety, touching a gun is the same as handling it.

- Always handle a gun as if it were loaded.
- Before loading, always engage the safety to prevent inadvertent firing. Keep your finger out of the trigger guard and put it on the trigger only when you want to shoot.
- Use only ammunition that has been approved for this weapon.
- Always point the muzzle in a safe direction.
- Shooting is permitted only within one's own home, on police-approved shooting ranges and on enclosed private property where there is no risk of projectiles leaving the premises. Keep the danger area of the projectile in mind.
- Never transport a loaded weapon. Load a weapon only when you intend to fire it.
- Never point a weapon at people or animals. Avoid ricocheting. Never shoot at smooth, hard surfaces or at water.
- Before shooting, make sure that the target and surroundings are safe.
- Always make sure that the gun is not loaded when you transport it or take it from another person.
- Make sure you can control the direction of the muzzle if you stumble or fall.
- Wear safety glasses when shooting.
- Store your weapon in a safe place and in unloaded condition. Keep it out of reach of unauthorized persons (untrained persons, children, persons under 18). Store ammunition separately.
- Give this gun only to persons who are thoroughly familiar with its use and who have reached the legally stipulated minimum age in the respective country.
- Modifications or repairs should be made only by authorized companies or gunsmiths.
- Never put down a loaded gun.
- Do not give your weapon to someone else unless you have unloaded it.

WARRANTY

During the legal warranty period, which begins on the date of purchase, Umarex will repair or replace your weapon at no charge provided the defect was not caused by you. Return your weapon to an authorized dealer along with a description of the problem and proof of purchase.

The air guns manufactured by UMAREX GmbH & Co. KG are made according to the regulations of the PTB (Physikalisch-Technische Bundesanstalt), German federal law, the CIP regulations and the technical know-how of UMAREX GmbH & Co. KG.

We will not assume any liability whatsoever if this product is exported to territories outside of Germany and as a consequence does not comply with domestic legal requirements of these territories. It will be the sole responsibility of the importer to ensure compliance with local laws and regulations.



EN SAFETY DIRECTIONS



DESCRIPTION OF PARTS



SAFETY

CAUTION

For your own safety and the safety of others, carefully read these instructions before trying to shoot this weapon. Buyers and owners must observe all rules concerning the use and ownership of air guns. Modifying this weapon may result in a change of its classification under weapons law and is therefore prohibited. In such cases the manufacturer's warranty will immediately become void.

REPAIR

A weapon that does not work right is dangerous. Do-it-yourself repairs are difficult, and incorrect assembly can lead to dangerous malfunctions.

Caution:

Have your gun inspected and repaired only by an authorized dealer or gunsmith.

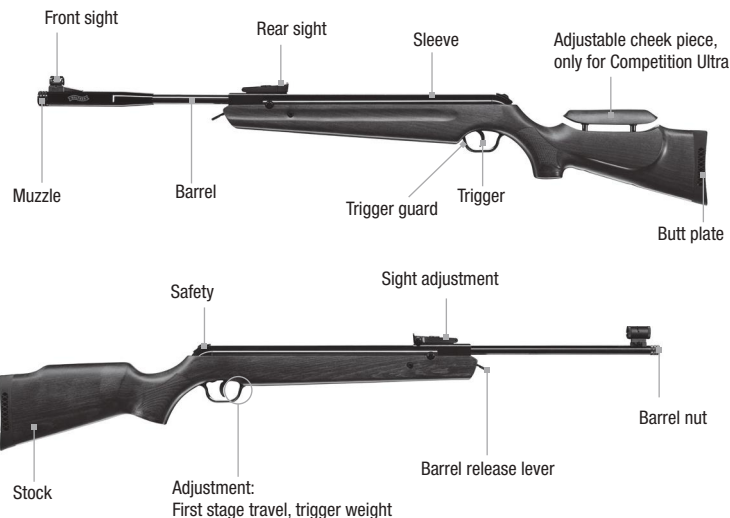

TECHNICAL DATA

System	Air rifle / break-barrel		
Energy source	Spring-piston		
Safety	Automatic		
Trigger	adjustable match trigger (first stage travel and trigger pull)		
Number of rounds	1 pellet (single shot)		
Barrel length	450 mm		
Total length	1095 mm		
Total width	54 mm		

Model	Challenger / Challenger Ultra			Master / Master Ultra			Competition Ultra		
Caliber	4,5mm	4,5mm	5,5mm	4,5mm	4,5mm	5,5mm	4,5mm	4,5mm	5,5mm
Energy	7.5 J	23 J	16 J	7.5 J	23 J	16 J	7.5 J	23 J	16 J
Projectile speed	175m/s	295m/s	175m/s	175m/s	295m/s	175m/s	175m/s	295m/s	175m/s
Weight	3,8 kg			4,2 kg			4,4 kg		
Stock	Synthetic stock			Wooden stock			Wooden stock		



SAFETY

Your rifle has a trigger safety which automatically engages each time it is cocked. To release the safety, push the lever into the front position as shown in the picture.



CAUTION

Only handle the weapon when the safety is engaged. Always make sure that the muzzle points in a safe direction.



SAFETY



SAFE



FIRE



ADJUSTING THE METAL TUNING TRIGGER

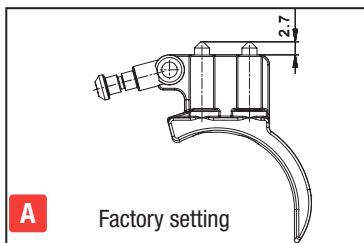

A Factory setting

When the rifle comes from the factory, the trigger is preset as shown in Figure A. Adjust only one screw at a time, and test to see the effect on the rifle's operation. Turn the screw in to reduce the trigger weight and trigger travel. Turn the screw out to increase the trigger weight and trigger travel.



ADJUSTING THE STANDARD TRIGGER

EN



① Adjustment of first stage travel

The first stage travel, i.e. the path of the trigger finger piece up to the let-off point, can be individually adjusted.

② Adjustment of trigger weight

The trigger weight is continuously adjustable. Turn the screw 2 to the right (clockwise) to increase the trigger weight. Turn the screw to the left (counterclockwise) to reduce the trigger weight, as shown in the pictures.

Adjustment of first stage travel

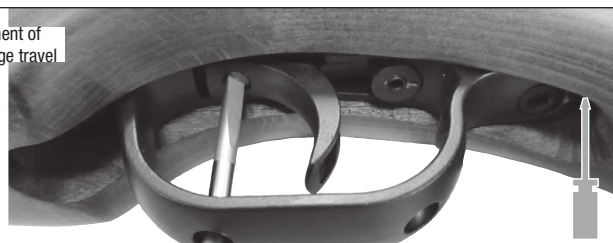

Adjustment of trigger weight



SW 2 mm



COCKING AND LOADING

CAUTION

- Do not keep the spring piston cocked for a long period. This can lead to accidents and can also cause fatigue of the spring, impairing the air rifle's performance.
- Do not dry fire the rifle (without a projectile). This might damage it.

NOTE:

The safety is automatically engaged when the rifle is cocked.

To cock the rifle, press the barrel release lever and push the barrel down until you hear the trigger click into place. Load a pellet into the back of the barrel as shown in the picture. Never use faulty or deformed pellets.

CAUTION

Caution! Always hold the barrel with one hand when cocking and loading. Never pull the trigger when the barrel is broken open. The barrel would jump up, bend and possibly cause injuries. The stock could also crack or break. **This would void the warranty.**

CAUTION: Do not use unsuitable projectiles like darts. Air rifles with a rifled barrel must have pellets of the right caliber.

Push the barrel back to its original position. The rifle is now ready to fire, with the safety engaged.

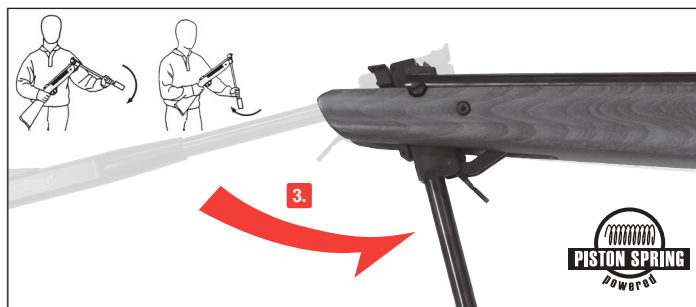
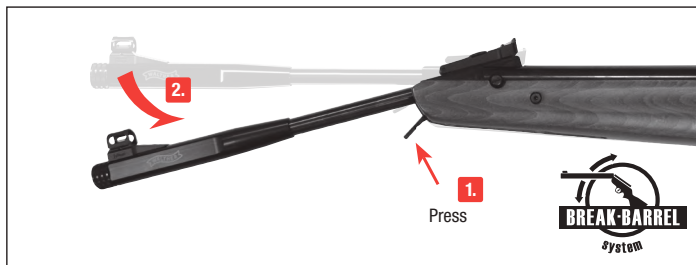



AIMING

EN

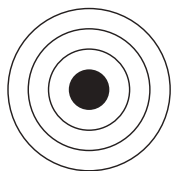

Ideal

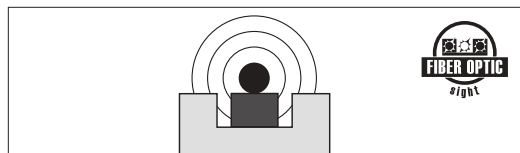

Wrong

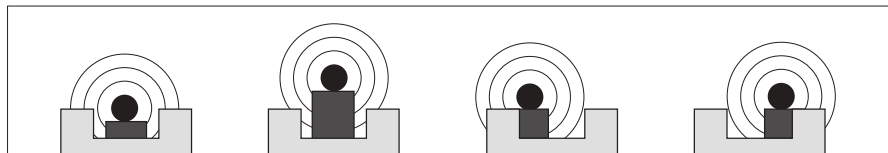

ADJUSTING THE SIGHT

The open front sight can be adjusted for both windage and elevation, as shown in the pictures.

The rifle comes with several different front sight posts. Remove the front sight screw to change them.



WINDAGE ADJUSTMENT

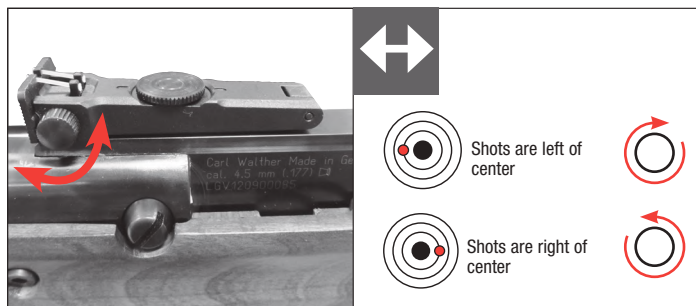

ELEVATION ADJUSTMENT

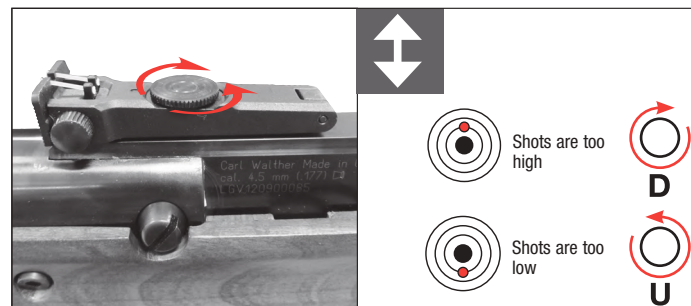



EN



SHOOTING



CAUTION

- Only handle the weapon when the safety is engaged.
- Always make sure that the muzzle points in a safe direction.
- This is a high-energy rifle. Only use targets which the projectile cannot penetrate.

Caution! Do not shoot the rifle when it is not loaded. The full recoil puts a very high strain on it.

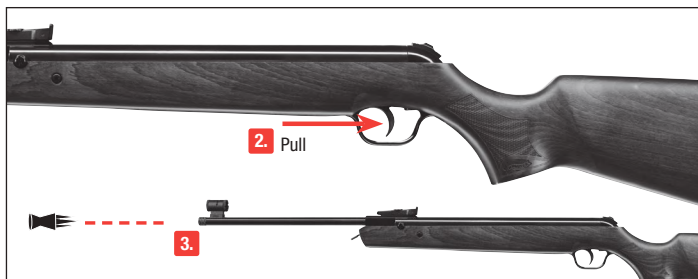

When shooting a spring-piston rifle, do not hold it too firmly. Otherwise your shots will be off target. Different pellets will give different results. Before shooting, make sure that the target and surroundings are safe. Then pull the trigger smoothly. Keep your eye on the target for a few seconds after firing. Remember that a change in your firing position will affect the impact point.

Caution! Avoid touching your face and mouth with your hands after handling pellets. Wash your hands thoroughly to remove any lead particles.

Decocking and unloading

If you decide not to shoot, proceed as follows:

To unload, first decock the rifle. To do so, break open the barrel until it locks the open position. While holding the barrel firmly with one hand, release the safety and pull the trigger.

CAUTION: Grasp the barrel firmly!

Then return the barrel to its original position.

To unload the rifle, open the barrel without cocking the spring piston and push the pellet out of the barrel using a cleaning rod.

Never pull the trigger when the rifle is cocked and the barrel is broken open (exception - decocking, see above). The barrel would jump up, bend and possibly cause injuries. The piston would hit the cocking rod, possibly breaking. The stock could also crack or break. **This would void the warranty.**

Never pull the trigger when the barrel is broken open (exception - decocking, see above).

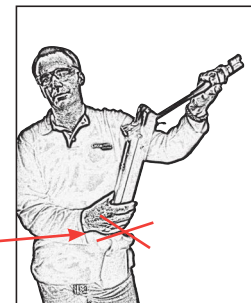



CLEANING THE BARREL, CARE

Make sure that your rifle is not cocked and not loaded.
Clean the barrel at regular intervals using materials intended for the purpose. Do not use wire brushes as these can damage the inside of the barrel.
Rub down the exterior metal parts occasionally using a cloth moistened with gun oil. Lightly oil the barrel hinges at regular intervals.

Caution! Do not store your air rifle with the spring piston cocked. This can cause fatigue, impairing the rifle's performance.

Cleaning pellets, item no. 3.2055

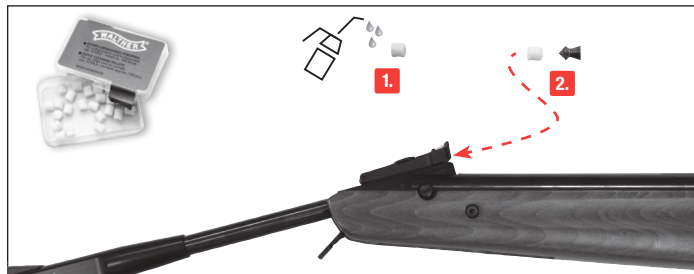

Cleaning rod, item (4.5 mm) and (5.5 mm) 3.2054

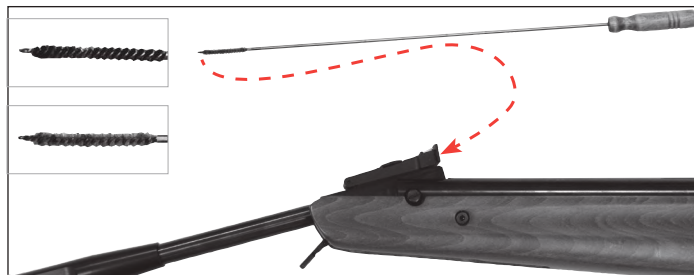

ACCESSORIES AND PROBLEMS

EN

Tuning trigger, metal
600.110



3-chamber silencer
2.4849



Walther spring grease, 10ml
3.2061

Walther piston grease, 30 ml
3.2060



PROBLEMS

POSSIBLE CAUSES

PROBLEMS	Safety is engaged	Dirt in barrel	Wrong ammunition	Ammunition not properly loaded	Break the barrel again. The piston should audibly engage.	Release the safety and pull the trigger. Check the rear screw for the trigger weight setting.
Poor shooting performance		●	●	●		
Gun does not shoot	●		●	●	●	
Slow projectile		●	●	●		
Gun cannot be cocked. Does not engage.						●



EN



CHEEK PIECE



The cheek piece of the Competition-Ultra model has two screws on the right for height adjustment.





SILENCER

EN

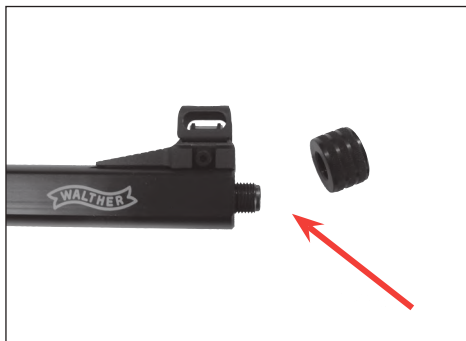

To attach the silencer, first remove the barrel nut.
Then screw on the silencer.



WALTHER

WALTHER LGV

Die neue Leisestärke.



[V]
VIBRATION
REDUCTION
SYSTEM

[S]
SUPER
SILENT
TECHNOLOGY

AIR RIFLE · LUFTGEWEHR · CARABINE À AIR COMPRIMÉ · CARABINA DE AIRE COMPRIMIDO
FUCILE AD ARIAN COMPRESSA · ПНЕВМАТИЧЕСКАЯ ВИНТОВКА · BROŃ PNEUMATYCZNA · HAVALI TÜFEK
cal. 4,5 mm (.177)
cal. 5,5 mm (.22)

EN Operating instructions 2 - 11 | DE Bedienungsanleitung 12 - 22 | FR Mode d'emploi 23 - 33 | ES Instrucciones de uso 34 - 44
IT Istruzioni per l'uso 45 - 55 | RU Инструкция по эксплуатации 56 - 66 | PL Instrukcja obsługi 67 - 77 | TR Kullanım Kılavuzu 78 - 88



Best Performance – WALTHER Luftgewehre für Sport und Freizeit.

Der Name Walther ist eng mit der Entwicklung innovativer Luftgewehre verbunden. Olympiasieger, Welt- und Europameister, begeisterte Vereins- und Freizeitschützen in aller Welt vertrauen der „Best Performance“ der bis ins Detail ausgereiften Lang-waffen. Carl Walther gehört heute zu den führenden Herstellern von Luftgewehren für Sport und Freizeit.

Die Erfolgsstory begann in den 50er und 60er Jahren des 20. Jahrhunderts. In dieser Zeit entwickelte sich das Schießen mit Luftdruckwaffen zum Breitensport. Dazu trug auch das erste von Fritz Walther entwickelte Federkolbengewehr bei, das Walther LG 51. Mit dem Meister-Luftgewehr LG 55 M gewann die Mannschaft der Schweiz bei der Weltmeisterschaft des Jahres 1966 Goldmedaillen. Den Anspruch, die Präzision zu erhöhen, setzte Walther 1964 in die Tat um – mit dem Walther LGV.





SICHERER UMGANG MIT WAFFEN



BENENNUNG



BEDIENUNG



PFLEGE



SICHERHEITSHINWEISE

Sie sollten mit der richtigen, sicheren Handhabung Ihrer Waffe vertraut sein. Im Hinblick auf die Grundregeln zum sicheren Schießen bedenken Sie, dass jede Berührung mit der Waffe als Handhabung verstanden wird.

- Behandeln Sie jede Waffe so, als wäre sie geladen.
- Die Waffe beim Laden stets sichern, so dass sich kein Schuss ungewollt lösen kann. Finger immer außerhalb des Abzugsbügels halten und nur zum Schuss an den Abzug legen.
- Verwenden Sie nur für diese Waffe vorgesehene Geschosse.
- Halten Sie die Mündung stets in eine sichere Richtung.
- Das Schießen ist nur in der eigenen Wohnung, auf polizeilich zugelassenen Schießständen und im befriedeten Besitztum erlaubt, wenn das Geschoss dieses beim Schuss nicht verlassen kann. Hierbei den Gefahrenbereich des Geschosses beachten.
- Transportieren Sie niemals eine geladene Waffe. Laden Sie nur, wenn Sie schießen möchten.
- Waffe niemals auf Menschen oder Tiere richten. Vermeiden Sie Querschläger. Schießen Sie niemals auf glatte, harte Oberflächen oder auf Wasserflächen.
- Vergewissern Sie sich vor dem Schuss, dass Ziel und Umgebungsbereich sicher sind.
- Kontrollieren Sie immer, ob die Waffe ungeladen ist, wenn Sie sie transportieren oder von einer anderen Person übernehmen.
- Vergewissern Sie sich, dass Sie, auch beim Stolpern oder Stürzen die Richtung der Mündung kontrollieren können.
- Aus Sicherheitsgründen sollte beim Schießen eine Schutzbrille getragen werden.
- Aufbewahren der Waffe stets sicher und ungeladen vor unerlaubtem Zugriff Unbefugter (ungeschulte Personen, Kinder, Personen unter 18 Jahren) und getrennt von der Munition.
- Weitergabe dieser Waffe mit der Bedienungsanleitung nur an Personen
 - die mit der Handhabung dieser Waffe genauestens vertraut sind und
 - die über das entsprechende Mindestalter nach dem Waffengesetz in dem jeweiligen Land verfügen.
- Jegliche Veränderungen oder Reparaturen von Waffen sollten nur von fachkundigen Firmen oder vom Büchsenmacher durchgeführt werden.
- Legen Sie niemals eine geladene Waffe aus der Hand.
- Geben Sie nur entladene Waffen an andere Personen weiter.

GARANTIE

Innerhalb des gesetzlich festgelegten Zeitraumes ab Kaufdatum repariert oder ersetzt Ihnen die Fa. Umarex Ihre Waffe kostenlos, falls der Defekt nicht durch Eigenverschulden aufgetreten ist. Geben Sie die Waffe einem autorisierten Händler, beschreiben Sie ihm das Problem und fügen Sie den entsprechenden Kaufbeleg bei.

Die von UMAREX GmbH & Co. KG hergestellten Druckluftwaffen werden gemäß den Zulassungsvorschriften der Physikalisch-Technischer Bundesanstalt (PTB), dem Bundesgesetz, den CIP-Vorschriften und dem waffen-technischen Know-how der Firma UMAREX GmbH & Co. KG hergestellt.

Somit übernehmen wir keine Haftung, falls diese Ware nach dem Export ins Ausland nicht den dort geltenden Rechtsvorschriften entsprechen sollte und dem Besitzer/Käufer juristische Schwierigkeiten und Konsequenzen daraus entstehen sollten.



SICHERHEITSHINWEISE



BENENNUNG

DE



ACHTUNG

Zu Ihrer eigenen und zur Sicherheit anderer lesen Sie die Bedienungsanleitung vollständig und sorgfältig durch, bevor Sie mit der Waffe den ersten Versuch zu Schießen unternehmen. Käufer und Besitzer haben die Pflicht, alle Regeln über den Gebrauch und den Besitz von Druckluftwaffen zu befolgen. Jede Änderung an dieser Waffe kann zu einer Änderung der waffenrechtlichen Einstufung führen und ist somit unzulässig. Die Gewährleistung des Herstellers erlischt in diesem Fall sofort.

REPARATUR

Eine Waffe, die nicht einwandfrei funktioniert, ist gefährlich. Es ist schwierig, eine Waffe selbst zu reparieren, und falscher Zusammenbau kann zu gefährlichen Funktionsstörungen führen.

Achtung:

Lassen Sie die Waffe nur von einem autorisiertem Fachhändler/Büchsenmacher überprüfen und reparieren.

TECHNISCHE DATEN

System	Luftgewehr / Kipplauf								
Energiequelle	Kolben-Feder								
Sicherung	Automatisch								
Abzug	einstellbarer Match-Abzug (Vorzugweg und Abzugkraft)								
Schusszahl	1 Diabolo (1-schüssig)								
Lauflänge	450 mm								
Gesamtlänge	1095 mm								
Gesamtbreite	54 mm								
Gesamthöhe	200 mm								

Modell	Challenger / Challenger Ultra			Master / Master Ultra			Competition Ultra		
Kaliber	4,5mm	4,5mm	5,5mm	4,5mm	4,5mm	5,5mm	4,5mm	4,5mm	5,5mm
Energie	7.5 J	23 J	16 J	7.5 J	23 J	16 J	7.5 J	23 J	16 J
Geschwindigkeit	175m/s	295m/s	175m/s	175m/s	295m/s	175m/s	175m/s	295m/s	175m/s
Gewicht	3,8 kg			4,2 kg			4,4 kg		
Schaft	Kunststoffschaft			Holzschaft			Holzschaft		

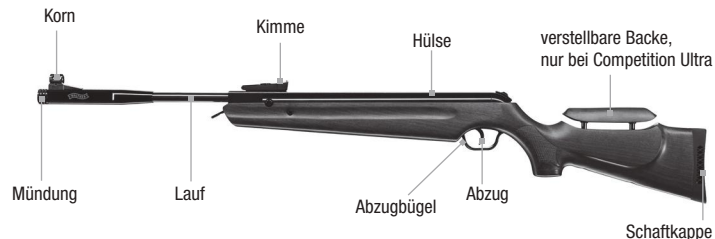

SICHERUNG

Das Gewehr hat eine Abzugsicherung, die Ihre Waffe bei jedem Spannvorgang automatisch sichert. Zum Entsichern schieben Sie den Sicherungshebel in die vordere Position. Siehe Abbildungen!



ACHTUNG

Hantieren Sie nur mit der Waffe, wenn diese gesichert ist. Achten Sie stets darauf, dass die Mündung in eine sichere Richtung zeigt.



DE  **SICHERUNG**



SAFE

FIRE



 **EINSTELLUNG METALL-TUNING ABZUG**

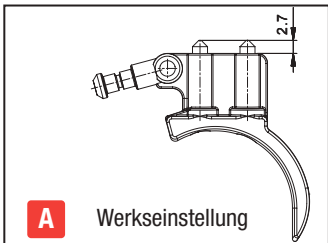

A Werkseinstellung

Im Auslieferungszustand ist der Abzug, standardmäßig eingestellt (Bild A). Verstellen Sie immer nur eine Schraube und testen Sie die Funktion und Auswirkung. Durch eindrehen der Schraube verringern sich Kraft und Wege. Durch herausdrehen verlängern sich Wege und erhöhen sich die Abzugkräfte.

 **EINSTELLUNG STANDART ABZUG**



1 Einstellung Vorzugsweg
Der Vorzugweg, d.h. der Weg der Abzugszunge bis zum Druckpunkt, ist individuell einstellbar.

2 Einstellung Abzugsgewicht
Das Abzugsgewicht ist individuell und stufenlos einstellbar. Durch drehen der Schraube 2 nach rechts (Uhrzeigersinn) wird das Abzugsgewicht erhöht. Durch Drehen der Schraube nach links (Gegenuhrzeigersinn) wird das Abzugsgewicht verringert. Siehe Abbildungen!

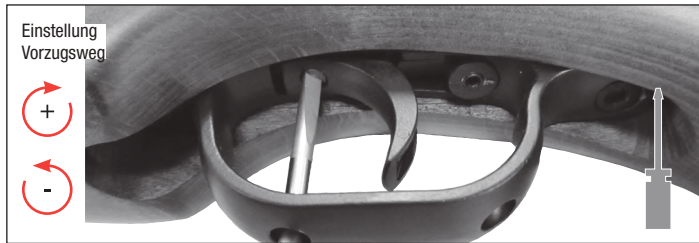



SPANNEN UND LADEN

DE

ACHTUNG

- Lassen Sie das Luftgewehr nicht für längere Zeit mit gespannter Kolbenfeder stehen. Dies kann zu Unfällen führen und außerdem kann die Kolbenfeder ermüden, wodurch die Schussleistung der Waffe Schaden nimmt.
- Die Waffe nicht leer (ohne Geschoss) abfeuern. Es besteht die Gefahr einer Beschädigung der Waffe.

HINWEIS:

Nach dem Spannen ist die Waffe automatisch gesichert.

Zum Spannen betätigen Sie den Laufentriegelungshebel und kippen den Lauf soweit nach unten, bis der Abzug hörbar einrastet. Das Diabolo wird am hinteren Ende des Laufs geladen.

Siehe Abbildung!

Verwenden Sie niemals fehlerhafte oder deformierte Diabolo.

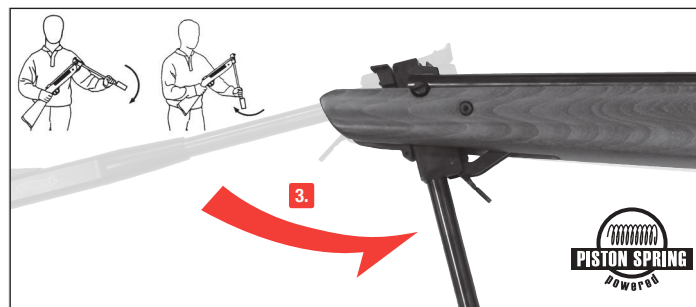
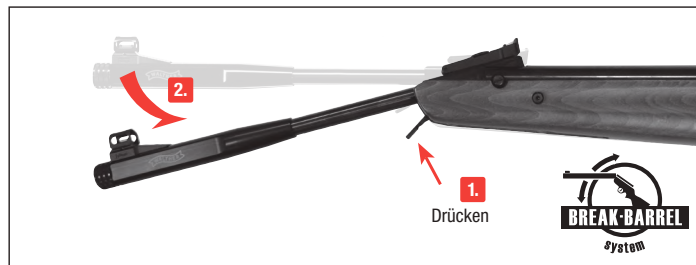

ACHTUNG

Achtung! Halten Sie beim Spannen und Laden immer mit einer Hand den Lauf fest. Betätigen Sie nie den Abzug, wenn der Lauf abgeknickt ist. Der Lauf würde nach oben schlagen, sich verbiegen und eventuell zu Verletzungen führen! Ein angerissener oder gebrochener Schaft wäre das Ergebnis. **Jede Gewährleistung würde entfallen.**

Achtung! Schießen Sie nicht mit ungeeigneten Geschossen, wie zb. Federbolzen. Für Luftgewehre mit gezogenem Lauf sind nur Diabolo in passendem Kaliber geeignet.

Führen Sie den Lauf zurück in seine Ausgangstellung. Das Gewehr ist jetzt schussbereit und gesichert.

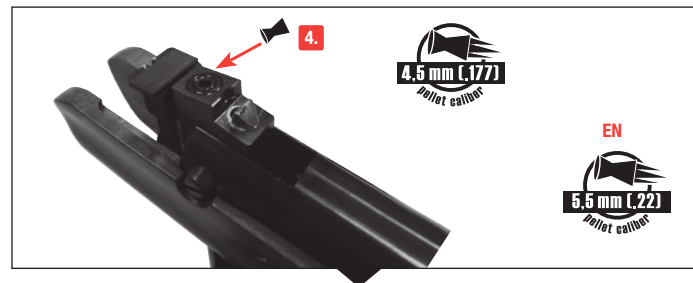



DE  **ZIELEN**

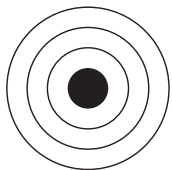

Ideal

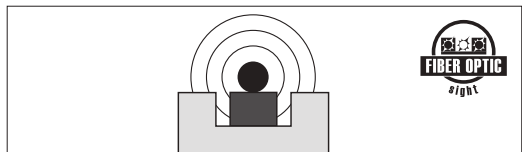

Falsch

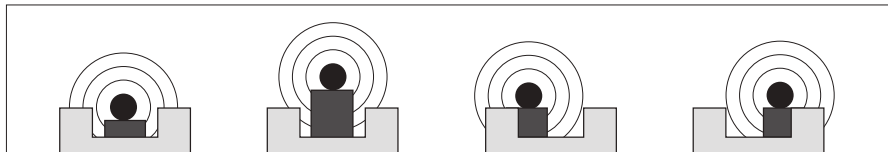

 **VISIERUNG EINSTELLEN**

Die Kimme der offenen Visierung Ihres Luftgewehrs ist seitlich und in der Höhe verstellbar. Siehe Abbildungen!

Im Lieferumfang sind verschiedene Kornblätter enthalten. Nach dem Entfernen der Kornschraube, können Sie die Kornblätter wechseln. Siehe Abbildungen!



SEITENVERSTELLUNG

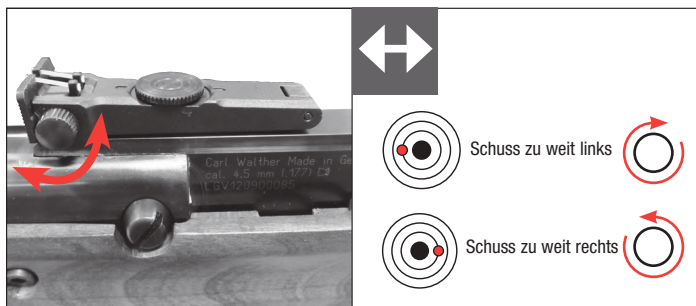

HÖHENVERSTELLUNG

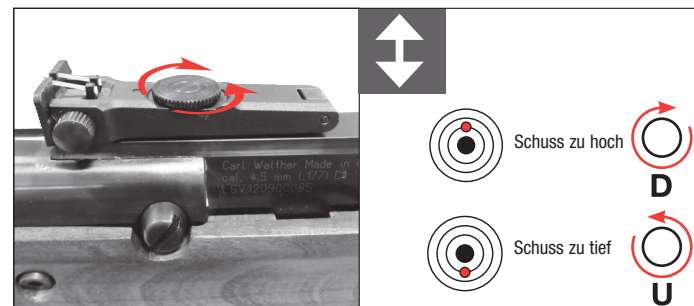



! ACHTUNG

- Hantieren Sie nur mit der Waffe, wenn diese gesichert ist.
- Achten Sie stets darauf, dass die Mündung in eine sichere Richtung zeigt.
- Wegen der hohen Energie der Waffe benutzen Sie nur Ziele, die nicht von den Geschossen durchdrungen werden können.

Achtung! Das Schießen mit ungeladenem Gewehr ist zu vermeiden, da der ungehemmte Prellschlag zu sehr hoher Beanspruchung des Gewehrs und des Zielfernrohrs führt.



Beim Schießen mit Federkolbengewehren ist zu beachten, dass das Gewehr nicht zu fest im Anschlag gehalten wird. Ungenaue Schüsse wären die Folge. Auch verschiedene Diabolosorten erzielen unterschiedliche Ergebnisse.

Vergewissern Sie sich vor dem Schuss, dass Ziel und Umgebungsbereich sicher sind. Dann ziehen Sie den Abzug ruhig durch. Nach dem Abziehen bleiben Sie noch einige Sekunden auf der Zielscheibe.

Beachten Sie, dass eine Veränderung des Anschlages die Trefferlage verändert.

Achtung! Vermeiden Sie den Kontakt mit Ihren Händen zu Gesicht und Mund, wenn Sie Luftgewehrkugeln in der Hand hatten. Waschen Sie gründlich Ihre Hände, um die Bleipartikel zu entfernen.

Entspannen und Entladen

Falls Sie sich entschließen, doch nicht zu schießen, gehen Sie folgendermaßen vor:

Zum Entladen entspannen Sie zuerst das Gewehr: Dazu knicken Sie den Lauf bis in die hintere Rastposition und halten Sie den Lauf mit einer Hand sicher fest, entsichern Sie Ihr Gewehr und betätigen Sie den Abzug.

ACHTUNG! Den Lauf sicher festhalten!

Dann führen Sie den Lauf langsam in seine Ausgangsposition.

Zum Entladen, öffnen Sie den Lauf, ohne die Kolbenfeder zu spannen und drücken Sie das Diabolo mit einem Putzstock aus dem Lauf.

Betätigen Sie nie den Abzug, wenn das Gewehr gespannt und der Lauf abgекnickt ist (Ausnahme - Entspannen, s.o.). Der Lauf würde nach oben schlagen, sich verbiegen und eventuell zu Verletzungen führen! Der Kolben schlägt auf das Spanngestänge und kann brechen. Ebenso kann es zu gerissenen oder gebrochenen Schäften kommen.

Jede Gewährleistung würde entfallen.

Bei geknicktem Gewehr nie den Abzug betätigen (Ausnahme - Entspannen, s.o.)

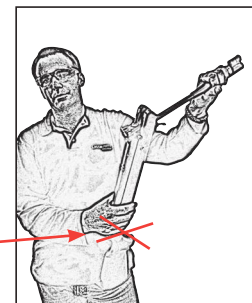



DE



LAUFREINIGUNG UND PFLEGE

Vergewissern Sie sich, dass Ihr Gewehr ungespannt und ungeladen ist.
 In regelmäßigen Abständen sollte der Lauf mit dafür vorgesehenen Hilfsmitteln geputzt werden.
 Von der Reinigung mit Drahtbürsten wird abgeraten, weil das Laufinnere beschädigt werden könnte.
 Äußere Metallteile sollten hin und wieder mit einem leicht in Waffenöl getränktem Tuch abgerieben werden und die Scharniere am Lauf sollten regelmäßig leicht geölt werden.

Achtung! Lagern Sie Ihr Luftgewehr nicht mit gespannter Kolbenfeder. Die Kolbenfeder könnte ermüden, wodurch die Schussleistung geringer wird.

Reinigungspropfen Artikel Nr. 3.2055

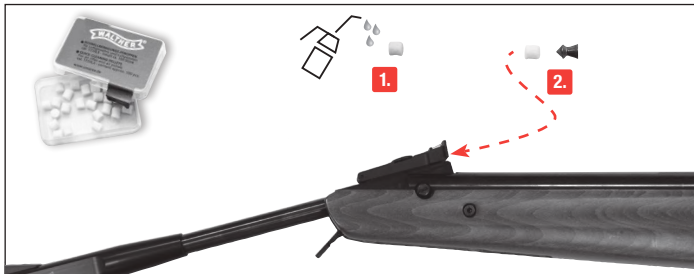

Reinigungsstab Artikel Nr. cal. 4,5 mm / cal. 5,5 mm 3.2054

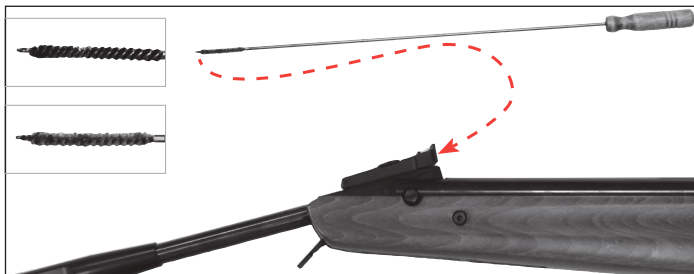

ZUBEHÖR UND PROBLEME

Tuning-Abzug aus Metall
 600.110



3-Kammer Schalldämpfer
 2.4849

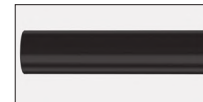

Walther Federfett, 10ml
 3.2061

Walther Kolbenfett, 30ml
 3.2060



PROBLEME

MÖGLICHE GRÜNDE

PROBLEME	Waffe gesichert	Lauf verschmutzt	Falsche Munition	Munition falsch geladen	Nochmals Lauf knicken, bis der Kolben hörbar einrastet	Ensisichern und Abzug betätigen, Einstellungen der Abzugskraft an der hinteren Schraube überprüfen.
schlechte Schussleistung		●	●	●		
Waffe schießt nicht	●		●	●	●	
geringe Geschwindigkeit		●	●	●		
Waffe lässt sich nicht spannen. Rastet nicht ein						●



SCHAFTBACKE

DE



Mit den beiden Schrauben an der rechten Seite kann die Schaftbacke des Modells Competition-Ultra in der Höhe verstellt werden.

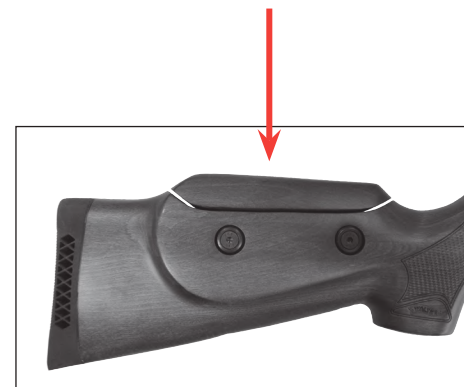



DE



SCHALLDÄMPFER

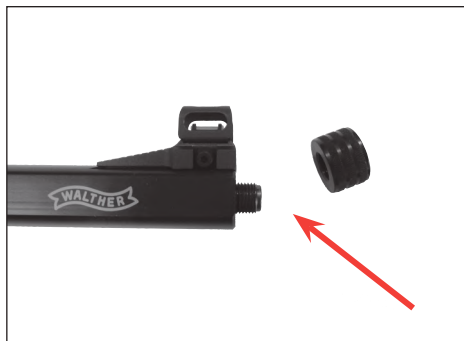

Um den Schalldämpfer anzubringen, muss erst die Laufmutter entfernt werden.
Danach kann der Schalldämpfer aufgeschraubt werden.





WALTHER LGV

The Sound of Silence.



AIR RIFLE · LUFTGEWEHR · CARABINE À AIR COMPRIMÉ · CARABINA DE AIRE COMPRIMIDO
FUCILE AD ARIAN COMPRESSA · ПНЕВМАТИЧЕСКАЯ ВИНТОВКА · BROŃ PNEUMATYCZNA · HAVALI TÜFEK
cal. 4,5 mm (.177)
cal. 5,5 mm (.22)

EN Operating instructions 2 - 11 | DE Bedienungsanleitung 12 - 22 | FR Mode d'emploi 23 - 33 | ES Instrucciones de uso 34 - 44
IT Istruzioni per l'uso 45 - 55 | RU Инструкция по эксплуатации 56 - 66 | PL Instrukcja obsługi 67 - 77 | TR Kullanım Kilavuzu 78 - 88



VIBRATION
REDUCTION
SYSTEM



SUPER
SILENT
TECHNOLOGY



Best Performance - Carabines à air Walther pour le tir sportif et de loisir.

Le nom Walther est étroitement lié au développement de carabines à air comprimé novatrices. Les Champions olympiques, champions du monde et d'Europe, les passionnés de tir amateurs et en club du monde entier font confiance aux performances optimales des armes longues conçues dans le souci du plus petit détail. Carl Walther fait aujourd'hui partie des plus grands fabricants de carabines à air comprimé pour les activités sportives et de détente.

Cette réussite prend ses racines dans les années 50 et 60 du siècle dernier. A cette époque, le tir avec des armes à air comprimé devenait un sport de masse. Le Walther LG 59, la première carabine à piston-ressort développée par Fritz Walther, a également contribué à cette évolution. En 1966, c'est avec la carabine à air comprimé LG 55 M que l'équipe suisse remporte la médaille d'or au Championnat du monde de 1966. Walther parvient à son objectif d'une plus grande précision en 1964 avec le Walther LGV.



MANIEMENT DES ARMES EN TOUTE SÉCURITÉ

FR



DÉSIGNATION DES PIÈCES



UTILISATION



ENTRETIEN



CONSIGNES DE SÉCURITÉ

Vous devez être habitué à manipuler votre arme correctement et de manière sûre. En considération des règles de base pour tirer en toute sécurité, n'oubliez pas que tout contact avec l'arme est considéré comme une manipulation.

- Maniez toujours l'arme comme si elle était chargée.
- Enclenchez toujours la sûreté avant de charger l'arme afin d'éviter tout tir involontaire. Ne mettez jamais le doigt sur la détente avant d'être prêt à tirer.
- Utilisez seulement les munitions prévues pour cette arme.
- Pointez toujours l'arme dans une direction sûre.
- Il n'est permis de tirer avec cette arme que dans le propre lieu de résidence du propriétaire, dans des zones de tir autorisées par la police et dans une propriété sécurisée, à condition que le projectile ne puisse pas sortir de la zone de tir. Pour cela, veuillez prêter attention à la portée des projectiles.
- Ne transportez jamais une arme chargée. Armez-la seulement lorsque vous êtes prêt à tirer.
- Ne pointez jamais l'arme vers des personnes ou des animaux. Évitez les tirs pouvant ricocher. Ne tirez jamais sur des surfaces lisses ou dures ou sur l'eau.
- Avant de tirer, assurez-vous que la cible et les alentours ne présentent aucun danger.
- Vérifiez toujours que l'arme est déchargée avant de la transporter ou lorsque vous la recevez d'autrui.
- Veillez à maîtriser la direction dans laquelle l'arme est pointée même si vous trébuchez ou tombez.
- Pour des raisons de sécurité, portez des lunettes de protection lorsque vous tirez.
- Rangez toujours l'arme déchargée, sûreté enclenchée, séparée des munitions, et hors de portée des personnes non autorisées (personnes non formées au maniement, enfants, mineurs).
- Ne remettez cette arme, accompagnée du mode d'emploi, qu'à des personnes connaissant parfaitement le maniement de cette arme et ayant atteint l'âge minimal légal selon la loi applicable aux armes dans le pays concerné.
- Toute modification ou réparation de l'arme doit être effectuée par une entreprise spécialisée ou un armurier.
- Ne posez jamais une arme chargée.
- Déchargez toujours l'arme avant de la remettre à d'autres personnes.

GARANTIE

La société Umarex s'engage à réparer ou à remplacer votre arme durant une période déterminée légalement à compter de la date d'achat, à condition que vous ne soyez pas responsable du défaut. Pour cela, remettez l'arme à un revendeur autorisé, décrivez-lui le problème et joignez le justificatif d'achat correspondant.

Les armes à air comprimé de la société UMAREX GmbH & Co. KG sont fabriquées conformément aux directives de conformité de l'institut allemand « Physikalisch-Technische Bundesanstalt (PTB) », à la loi fédérale, aux prescriptions CIP et au savoir-faire technique de la société UMAREX GmbH & Co. KG dans le domaine des armes.

Ainsi, nous ne pouvons être tenus responsables si, après exportation à l'étranger, cette marchandise ne répond pas aux prescriptions légales en vigueur dans le pays en question et si le possesseur/acheteur doit pour cette raison faire face à des difficultés juridiques ou toute autre conséquence pouvant découler de ce fait.



ATTENTION

Pour votre sécurité et celle des autres, veuillez lire attentivement tout le mode d'emploi avant de tirer pour la première fois avec cette arme. Les acheteurs et possesseurs d'armes ont pour obligation de respecter tous les règlements relatifs à l'utilisation et à la possession d'armes à air comprimé. Il est interdit de modifier l'arme, ceci pouvant entraîner un changement de classification légale de l'arme. En cas de non-respect de cette règle, la garantie du fabricant expire immédiatement.

RÉPARATION

Une arme qui ne fonctionne pas correctement est dangereuse. Il est difficile de réparer soi-même une arme et un assemblage incorrect peut entraîner de dangereux dysfonctionnements.

Attention :

Ne faites vérifier et réparer votre arme que par un spécialiste / armurier autorisé !

CARACTÉRISTIQUES TECHNIQUES

Système	Carabine à air comprimé / canon basculant								
Source d'énergie	ressort de piston								
Sûreté	Automatique								
Détente	détente match réglable (pré-course et force de détente)								
Nombre de tirs	1 diabolo (1 tir)								
Longueur du canon	450 mm								
Longueur totale	1095 mm								
Largeur totale	54 mm								

Modèle	Challenger / Challenger Ultra			Master / Master Ultra			Competition Ultra		
Calibre	4,5mm	4,5mm	5,5mm	4,5mm	4,5mm	5,5mm	4,5mm	4,5mm	5,5mm
Énergie	7.5 J	23 J	16 J	7.5 J	23 J	16 J	7.5 J	23 J	16 J
Vitesse du projectile	175m/s	295m/s	175m/s	175m/s	295m/s	175m/s	175m/s	295m/s	175m/s
Poids	3,8 kg			4,2 kg			4,4 kg		
Crosse	Crosse en plastique			Crosse en bois			Crosse en bois		

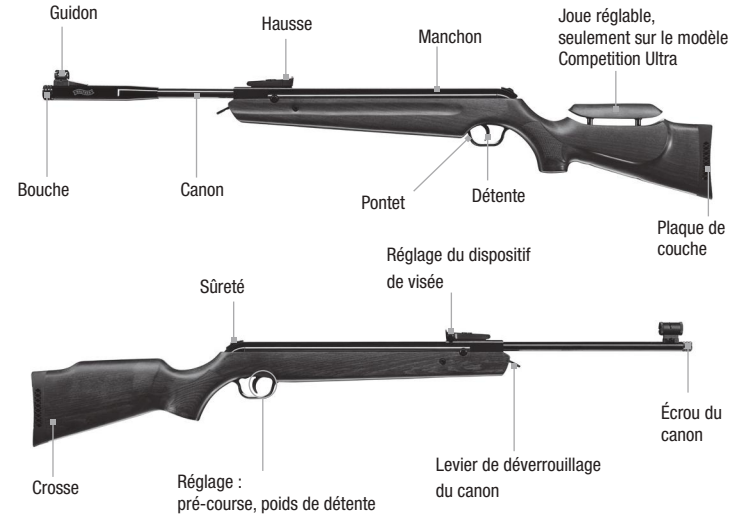

RÉGLAGE DE LA DÉTENTE

La carabine dispose d'une sûreté de détente qui sécurise automatiquement votre arme à chaque processus de chargement. Pour enlever la sûreté, poussez le levier de sûreté en position avant. Cf. illustrations !



ATTENTION

Ne manipulez l'arme que lorsque la sûreté est enclenchée. Veillez à toujours pointer la bouche de l'arme dans une direction sûre.



SÛRETÉ



SAFE



FIRE

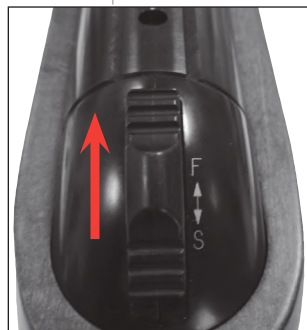

RÉGLAGE DÉTENTE TUNING MÉTAL

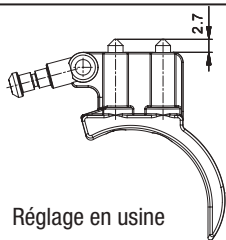

A

Réglage en usine

À la livraison, la détente est réglée de manière standard (figure A).

Ne réglez toujours qu'une seule vis à la fois et testez le fonctionnement et les effets. Le vissage de la vis entraîne la réduction de l'effort et de la course. Le dévissage rallonge les courses et augmente les efforts de détente.



RÉGLAGE DÉTENTE STANDARD

FR



1 Réglage de la pré-course

La pré-course, c'est-à-dire le trajet de la languette de détente jusqu'au point de poussée, peut être réglée individuellement.

2 Réglage du poids de détente

Le poids de détente peut être réglé individuellement et progressivement. Le poids de détente peut être augmenté en tournant la vis 2 vers la droite (sens des aiguilles d'une montre), et être diminué en tournant cette même vis vers la gauche (sens inverse des aiguilles d'une montre). Cf. illustrations !

Réglage de la pré-course



Réglage du poids de détente





FR



ARMEMENT ET CHARGEMENT

⚠ ATTENTION

- Ne laissez pas trop longtemps la carabine avec le ressort du piston comprimé. Cela peut entraîner des accidents et solliciter inutilement le ressort du piston, ce qui diminue les performances de tir de l'arme.
- Ne tirez pas à vide (sans projectile). Cela pourrait endommager l'arme.

REMARQUE :

Après armement, la sûreté de l'arme est automatiquement enclenchée.

Pour procéder à l'armement, actionnez le levier de déverrouillage du canon et abaissez le canon jusqu'à ce que la détente s'enclenche de manière audible. Le diabolos est introduit à l'extrémité arrière du canon. Cf. illustration !

N'utilisez en aucun cas des diabolos déformés ou défectueux.

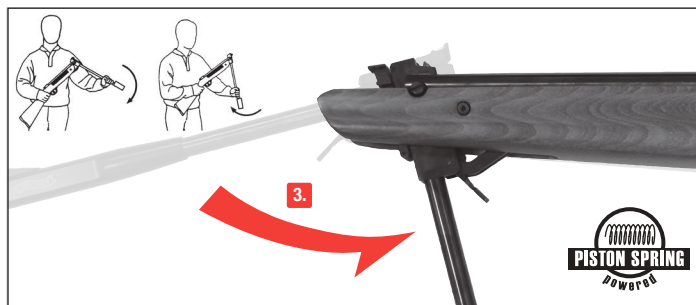
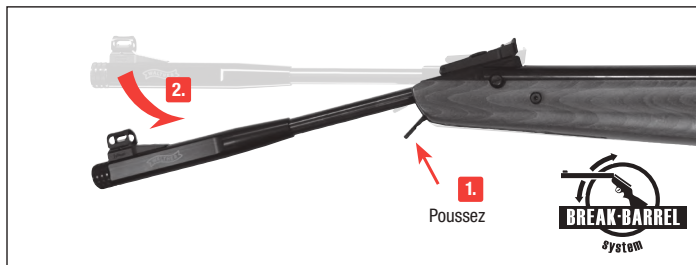

⚠ ATTENTION

Attention ! Lors de l'armement et du chargement, tenez toujours fermement le canon d'une main. N'actionnez jamais la détente lorsque le canon est ouvert. Le canon se rabattra vers le haut, se tordrait et pourrait entraîner des blessures ! La crosse pourrait également se casser ou se fendre. **Toute prestation de garantie serait alors exclue.**

Attention: Ne tirez pas avec des projectiles non appropriés, des fléchettes par exemple. Seuls des diabolos d'un calibre adapté doivent être utilisés avec les carabines à air comprimé à canon rayé.

Ramenez le canon dans sa position initiale. La carabine est à présent prête à tirer et la sûreté enclenchée.





VISER

FR

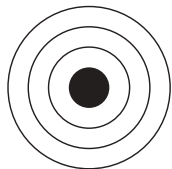

Idéal

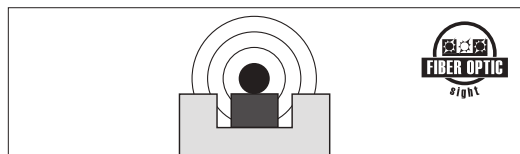

Mauvaise position

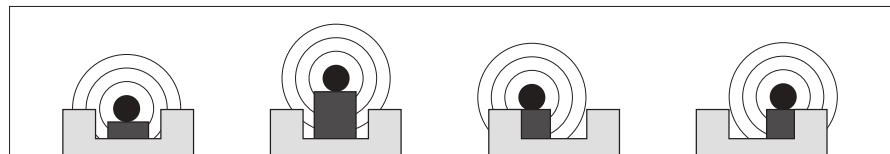

RÉGLAGE DU DISPOSITIF DE VISÉE

La hausse du dispositif de visée ouvert de votre carabine peut être réglée latéralement et en hauteur. Cf. illustrations !

Différents feuillets de guidon sont livrés avec la carabine. Vous pouvez changer le feuillet en dévissant la vis du guidon. Cf. illustrations !



RÉGLAGE LATÉRAL

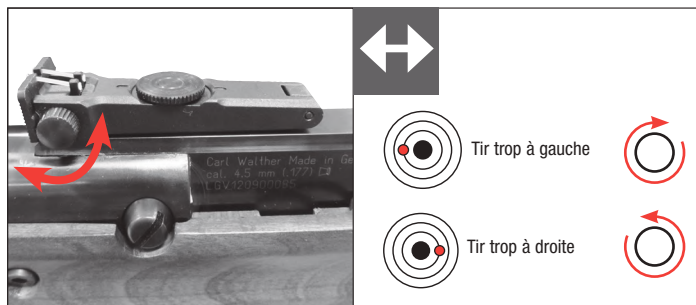

RÉGLAGE EN HAUTEUR

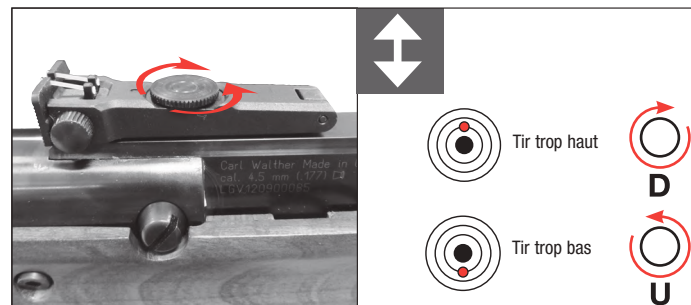



ATTENTION

- Ne manipulez l'arme que lorsque la sûreté est enclenchée.
- Veillez à toujours pointer la bouche de l'arme dans une direction sûre.
- En raison de la forte puissance de cette arme, n'utilisez que des cibles ne pouvant pas être transpercées par les projectiles.

Attention ! Veuillez éviter de tirer avec une arme non chargée, car la frappe à vide sans obstacle sollicite fortement la carabine.



Lorsque vous tirez avec une carabine à piston-ressort, vous devez veiller à ne pas tenir trop fermement la carabine. Il en résulterait une moins bonne précision de tir. Les résultats obtenus varient également en fonction des types de diabolos utilisés.

Avant de tirer, assurez-vous que la cible et les alentours ne présentent aucun danger. Appuyez doucement sur la détente. Après le tir, restez encore quelques secondes sur la cible. Considérez qu'un changement de la position de tir entraîne un déplacement de l'impact.

Attention ! Évitez de porter vos mains à votre visage et à votre bouche lorsque vous avez des munitions de carabine à air comprimé dans la main. Lavez-vous minutieusement les mains pour enlever les particules de plomb.

Désarmement et déchargement

Si vous décidez finalement de ne pas tirer, procédez de la manière suivante :

Pour le déchargement, désarmez tout d'abord la carabine. Pour cela, rabaissez le canon jusqu'à ce qu'il s'enclenche et maintenez-le fermement d'une main, enlevez la sûreté de votre carabine et actionnez la détente.

ATTENTION : Tenez fermement le canon !

Ramenez ensuite lentement le canon dans sa position initiale.

Pour décharger l'arme, ouvrez le canon sans comprimer le ressort du piston et expulsez le diabolo du canon à l'aide d'une tige de nettoyage.

N'actionnez jamais la détente lorsque la carabine est armée et le canon ouvert (exception – désarmement, voir ci-dessus). Le canon se refermerait, se tordrait et pourrait entraîner des blessures ! Le piston frappe la barre d'armement et peut rompre. Cela peut également casser ou fendre la crosse.

Toute prestation de garantie serait alors exclue.

Ne jamais actionner la détente lorsque la carabine est pléée (exception – désarmement, voir ci-dessus).

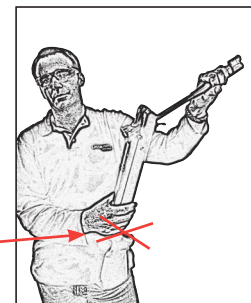



NETTOYAGE DU CANON ET ENTRETIEN

Assurez-vous que votre carabine est désarmée et déchargée.

Le canon doit être nettoyé à intervalles réguliers à l'aide d'accessoires et produits prévus à cet effet. Il est déconseillé d'utiliser des brosses métalliques, car celles-ci peuvent endommager l'intérieur du canon.

Les parties métalliques extérieures doivent être frottées de temps en temps avec un chiffon légèrement imbibé d'huile pour armes et les charnières du canon doivent être légèrement huilées à intervalles réguliers.

Attention ! Veillez à ce que le ressort du piston ne soit pas comprimé avant de ranger votre arme. Le ressort pourrait fatiguer ce qui diminuerait les performances de tir.

Tampon de nettoyage, réf. 3.2055

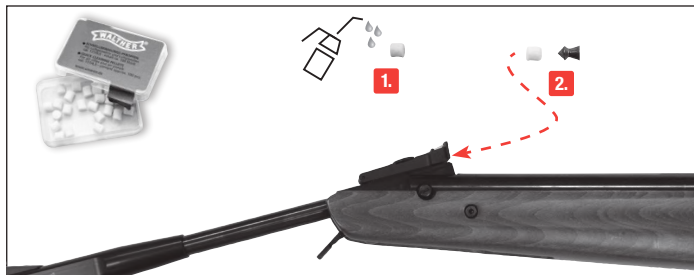

Tige de nettoyage, cal. 4,5 mm / cal. 5,5 mm réf. 3.2054

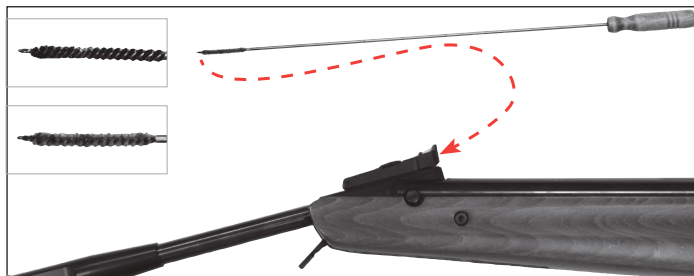

ACCESSOIRES ET DYSFONCTIONNEMENTS

FR

Détente en métal pour tuning
600.110



Silencieux 3 chambres
2.4849



Graisse Walther pour ressorts, 10ml
3.2061



Graisse pour piston Walther, 30ml
3.2060



DYSFONCTIONNEMENTS

CAUSES POSSIBLES

DYSFONCTIONNEMENTS	sûreté de l'arme enclenchée	canon encrassé	mauvaise munition	munition mal chargée	Plier à nouveau le canon jusqu'à ce que le piston s'enclenche de manière audible.	Désactiver la sûreté et actionner la détente. Vérifier les réglages de l'effort à la détente sur la vis arrière.
mauvaise performance de tir		●	●	●		
l'arme ne tire pas	●		●	●	●	
faible vitesse du projectile		●	●	●		
Impossible d'armer l'arme. Ne s'enclenche pas.						●



FR



CROSSE À JOUE



La crosse à joue du modèle Competition-Ultra peut être réglée en hauteur à l'aide des deux vis situées sur le côté droit.





SILENCIEUX

FR

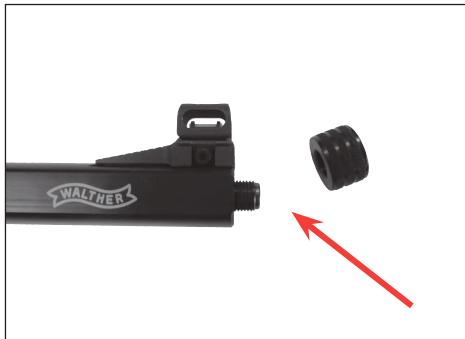

Pour fixer le silencieux, l'écrou du canon doit tout d'abord être retiré.
Le silencieux peut ensuite être vissé.



WALTHER

WALTHER LGV

The Sound of Silence.



[V]

VIBRATION
REDUCTION
SYSTEM

[S]

SUPER
SILENT
TECHNOLOGY

AIR RIFLE · LUFTGEWEHR · CARABINE À AIR COMPRIMÉ · CARABINA DE AIRE COMPRIMIDO
FUCILE AD ARIAN COMPRESSA · ПНЕВМАТИЧЕСКАЯ ВИНТОВКА · BROŃ PNEUMATYCZNA · HAVALI TÜFEK
cal. 4,5 mm (.177)
cal. 5,5 mm (.22)

EN Operating instructions 2 - 11 | DE Bedienungsanleitung 12 - 22 | FR Mode d'emploi 23 - 33 | ES Instrucciones de uso 34 - 44
IT Istruzioni per l'uso 45 - 55 | RU Инструкция по эксплуатации 56 - 66 | PL Instrukcja obsługi 67 - 77 | TR Kullanım Kılavuzu 78 - 88



Best Performance - Rifles de aire Walther para el deporte y recreación.

El nombre Walther está íntimamente ligado con la fabricación de rifles de aire comprimido innovadores. Los campeones olímpicos, campeones del mundo y de Europa y los amantes del tiro aficionado confían en la perfección técnica de estas armas. Carl Walther es hoy día uno de los fabricantes líder de armas de aire comprimido para deporte y recreación.

La historia de éxito comenzó en los años 1950 y 1960, cuando tiro con rifle de aire comprimido comenzó a ganar gran popularidad. El LG de 51, el primer rifle de resorte-pistón desarrollado por Walther, jugó un papel importante en este desarrollo. En 1966, el rifle de aire comprimido LG 55 fue usada por el equipo suizo que obtuvo de la medalla de oro en los campeonatos del mundo. Y en 1964, Walther sacó al mercado un rifle con una mayor precisión: el LGV Walther.





MANEJO SEGURO DE ARMAS



DESIGNACIÓN



MANEJO



CUIDADOS



INSTRUCCIONES DE SEGURIDAD

Ud. deberá estar familiarizado con el manejo correcto y seguro de su arma. Respecto a las reglas básicas para disparar con seguridad, considere cada contacto con el arma como parte de su manejo.

- Trate el arma como si siempre estuviera cargada.
- Cargue siempre el arma con el seguro activado para evitar disparos involuntarios.
- Mantenga el dedo siempre fuera del gatillo y colóquelo solamente cuando vaya a disparar.
- Utilice únicamente proyectiles específicos para esta arma.
- Mantenga la boca del arma siempre en una dirección segura.
- Sólo está permitido disparar el arma en la vivienda del propietario o en las zonas de tiro autorizadas por la policía, siempre y cuando el proyectil no pueda llegar más allá del área de tiro. Para ello, tenga presente siempre la distancia máxima de peligro del proyectil.
- Nunca transporte el arma cargada. Cárguela solamente cuando tenga intención de disparar.
- Nunca apunte con el arma hacia personas o animales. Evite los disparos en los que el proyectil pueda rebotar: nunca dispare sobre superficies lisas y duras, ni al agua.
- Antes de disparar, asegúrese de que el objetivo y el entorno sean seguros.
- Antes de transportar el arma o de recibirla de manos de otra persona compruebe siempre que está descargada.
- Asegúrese de poder controlar la dirección a la que apunta la boca de la pistola, aún en caso tropiezo o de caída del arma.
- Por motivos de seguridad, cuando vaya a disparar póngase siempre gafas protectoras.
- Guarde el arma siempre descargada, separada de la munición y en lugar seguro para evitar que personas no aptas (personas sin formación, niños) puedan acceder a ella.
- Entregue esta arma, junto con las instrucciones de uso, únicamente a aquellas personas que:
 - estén perfectamente familiarizadas con el manejo de esta arma
 - hayan cumplido la edad mínima correspondiente fijada por la legislación en materia de armas del país respectivo.
- Cualquier modificación o reparación del arma deberá llevarla a cabo una empresa especializada o un armero.
- Nunca deje sin vigilancia un arma cargada.
- Siempre que entregue un arma a otra persona, asegúrese de que está descargada.

GARANTIA

La empresa Umarex se responsabiliza de reparar o sustituir su producto sin coste alguno en el plazo legalmente fijado a partir de la fecha de compra, siempre que el defecto no sea responsabilidad del propio usuario. Entregue el arma a un comerciante autorizado, descríbalas el problema y adjunte el correspondiente comprobante de compra.

Las armas de aire comprimido de la empresa UMAREX GmbH & Co. KG se fabrican de conformidad con las normas de homologación del Instituto Federal PTB (Physikalisch-Technischer Bundesanstalt), con la Ley Federal alemana, la normativa que establece el centro CIP y la experiencia en fabricación de armas de UMAREX GmbH & Co. KG.

Por eso, no asumimos ninguna responsabilidad en el caso de que al exportar el arma a un país extranjero, ésta no cumpliera con la normativa legal local y el propietario o comprador tuviera que responder jurídicamente por dicho incumplimiento.



INSTRUCCIONES DE SEGURIDAD



ATENCIÓN

Por su propia seguridad y la de los demás, lea detenidamente las instrucciones de uso completas antes de disparar el arma por primera vez. Los vendedores y compradores están obligados a cumplir todas las normas de uso y posesión de armas de aire comprimido. Queda prohibida cualquier modificación de esta arma, ya que ello podría implicar un cambio en su clasificación legal. En caso de modificación quedaría extinguida de inmediato la garantía del fabricante.

REPARACIONES

Un arma que no funcione perfectamente es peligrosa. Es muy difícil reparar uno mismo un arma, y el ensamblaje incorrecto puede provocar fallos de funcionamiento peligrosos.

Atención:

La comprobación y reparación del arma debe dejarse en manos de especialistas autorizados o un armero.

DATOS TÉCNICOS

Sistema	Carabina de aire comprimido / cañón abatible								
Propulsión	Pistón-resorte								
Seguro	Automático								
Gatillo	Gatillo match ajustable (carrera previa y fuerza del gatillo)								
Número de disparos	1 Diábolo (de 1 disparo)								
Longitud del cañón	450 mm								
Longitud total	1095 mm								
Anchura total	54 mm								

Modelo	Challenger / Challenger Ultra			Master / Master Ultra			Competition Ultra		
Calibre	4,5mm	4,5mm	5,5mm	4,5mm	4,5mm	5,5mm	4,5mm	4,5mm	5,5mm
Energía	7.5 J	23 J	16 J	7.5 J	23 J	16 J	7.5 J	23 J	16 J
Velocidad del proyectil	175m/s	295m/s	175m/s	175m/s	295m/s	175m/s	175m/s	295m/s	175m/s
Peso	3,8 kg			4,2 kg			4,4 kg		
Culata	Culata de plástico			Culata de madera			Culata de madera		



DESIGNACIÓN

ES



AJUSTE DEL GATILLO

La carabina cuenta con un seguro en el gatillo que la asegura automáticamente cada vez que se arma. Para desactivar el seguro, lleve la palanca del seguro hasta la posición delantera. Véase las figuras correspondientes.



ATENCIÓN

Manipule el arma únicamente cuando tenga el seguro activado. Asegúrese siempre de que la boca del cañón apunte siempre en una dirección segura.



ES **SEGURO**



SAFE



FIRE



AJUSTE DEL GATILLO TUNING DE METAL

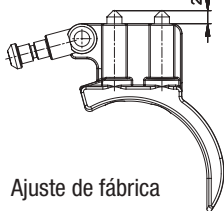

A Ajuste de fábrica

Cuando el rifle sale de la fábrica, el gatillo está preajustado como se muestra en la figura A.

Ajuste cada vez sólo un tornillo y compruebe el funcionamiento sobre el funcionamiento del rifle. Enroscando el tornillo se reduce la fuerza y la distancia. Desenroscando se aumenta la distancia y la fuerza del gatillo.

AJUSTE DEL GATILLO ESTÁNDAR



1 Ajuste de la carrera previa

La carrera previa, es decir, el recorrido de la lengüeta del gatillo hasta el punto de presión, puede ajustarse individualmente.

2 Ajuste del peso del gatillo

El peso del gatillo puede ajustarse de forma individual y en progresión continua. Girando el tornillo 2 hacia la derecha (sentido horario) se incrementa el peso del gatillo. Girando el tornillo hacia la izquierda (sentido antihorario) se reduce el peso del gatillo. Véase las figuras correspondientes.

Ajuste de la carrera previa

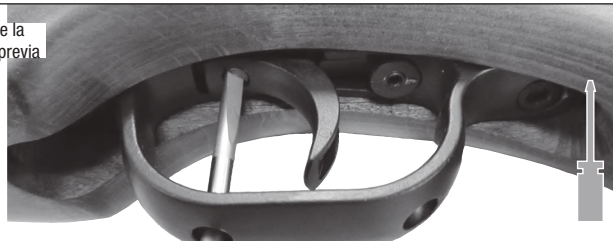

Ajuste del peso del gatillo



SW 2 mm



AMARTILLAR Y CARGAR

ES

⚠ ATENCIÓN

- No deje la carabina de aire comprimido con el resorte del pistón armado durante mucho tiempo. Esto puede provocar accidentes y además el resorte del pistón podría fatigarse y mermar la capacidad de disparo del arma.
- No dispare el arma en seco (sin proyectil). Existe el peligro de daños.

AVISO:

El seguro del arma se activa automáticamente tras el amartillado.

Para amartillar, accione la palanca de desbloqueo del cañón y gire el cañón hacia abajo hasta que se oiga que el gatillo ha encajado. El balín diábolo se cargará en el extremo trasero del cañón.

Véase la figura correspondiente.

Nunca usa balines diábolo defectuosos o deformados.

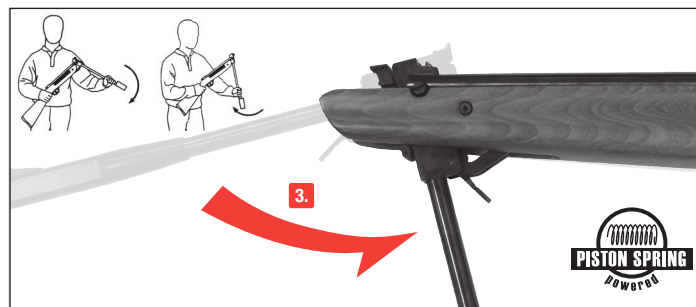
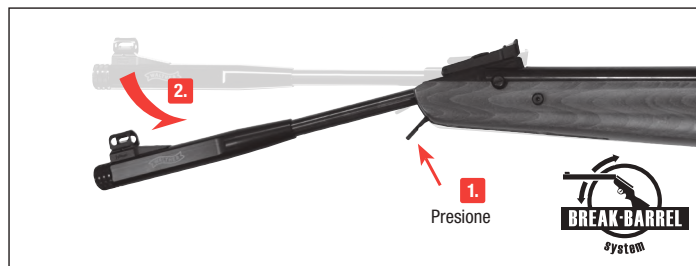

⚠ ATENCIÓN

¡Atención! A la hora de amartillar y cargar sostenga siempre el cañón firmemente con una mano. Nunca accione el gatillo cuando el cañón esté doblado. El cañón golpearía hacia arriba y se torcería y podría provocar lesiones. El resultado sería una culata agrietada o rota. **La garantía se extinguiría de inmediato.**

No emplee proyectiles inadecuados para esta arma, como por ejemplo, dardos. Para armas de aire comprimido con cañón de ánima rayada se deben usar balines diábolo en el calibre adecuado.

Lleve el cañón a su posición inicial. El arma está ahora lista para disparar y con el seguro activado.





ES



APUNTAR

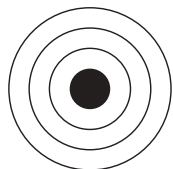

Ideal

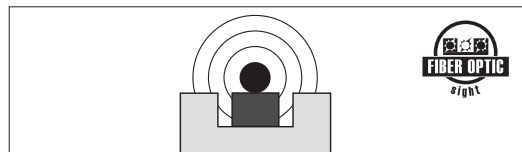

Erróneo

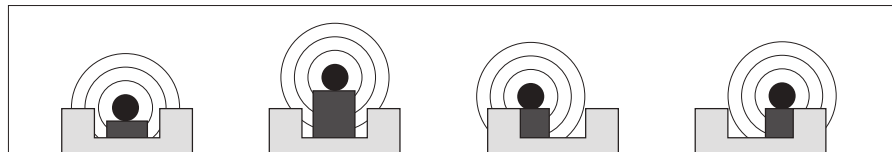

AJUSTE DE LA MIRA

La mira abierta de su arma de aire comprimido se puede ajustar lateralmente y en altura. Véase las figuras correspondientes.

En el volumen de suministro se incluye diferentes hojas de mira. Después de quitar el tornillo del punto de mira se pueden cambiar las hojas de la mira.



AJUSTE LATERAL

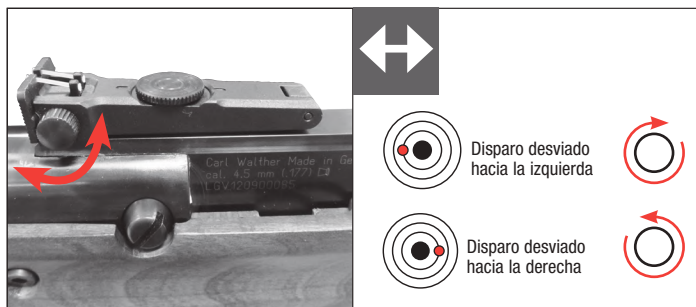

AJUSTE EN ALTURA

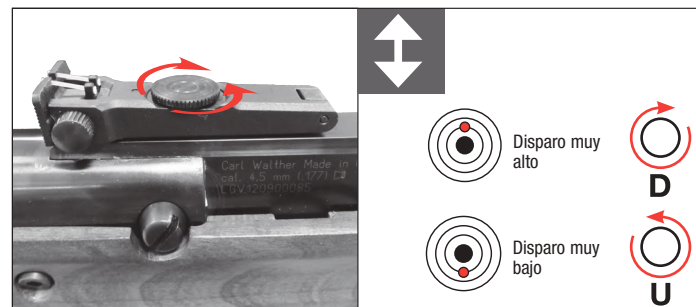



DISPARAR

ES

⚠ ATENCIÓN

- Manipule la pistola únicamente cuando tenga el seguro activado.
- Asegúrese siempre de que la boca del cañón apunte en una dirección segura.
- Debido a la alta energía del arma se tienen que seleccionar blancos que no puedan ser penetrados por el proyectil.

¡Atención! Evite disparar con el arma descargada, pues el golpe de retroceso incontrolado puede provocar una sollicitación muy elevada en la carabina.



Cuando dispare una carabina con accionamiento pistón/resorte tenga en cuenta de no sujetarla con demasiada firmeza. El resultado podrían ser disparos inexactos. También se debe tener en cuenta que con diferentes tipos de balines se obtienen diferentes resultados. Antes de disparar, asegúrese de que el objetivo y el entorno sean seguros. Después, apriete el gatillo tranquilamente. Después de apretar el gatillo siga apuntando algunos segundos al blanco. Tenga en cuenta que una modificación de la posición de disparo afectará la posición del punto de impacto.

¡Atención! Evite tocarse con las manos la cara y la boca si ha tocado balines para carabinas de aire comprimido. Lávese muy bien las manos a fin de eliminar las partículas de plomo.

Desarmar y descargar

Si decide no disparar siga las siguientes instrucciones:

Para descargar tendrá que desarmatillar primero el arma. Para ello se debe abatir el cañón hasta la última posición de retención y sujetarlo bien con una mano, descativar el seguro y apretar el gatillo.

ATENCIÓN: Sujete muy bien del cañón.

Después, lleve lentamente el cañón a su posición inicial.

Para desarmar el arma, abra el cañón, sin tensar el resorte del pistón, y saque el balín diábolo del cañón presionando con una varilla de limpieza.

Nunca accione el gatillo cuando el arma esté armada y el cañón doblado (excepción – desarmar, véase arriba). El cañón podría saltar, torcerse y provocar lesiones. El pistón golpea contra la barra de amartillado y puede romperse. Las consecuencias también podrían ser una culata agrietada o rota.

La garantía se extinguiría de inmediato.

Nunca apriete el gatillo si la carabina está doblada (excepción – desarmar, véase arriba).

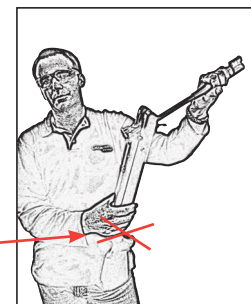



ES



LIMPIEZA Y CUIDADO DEL CAÑÓN

Asegúrese de que el arma esté desarmatillada y descargada.

El cañón debe limpiarse en intervalos regulares con materiales previstos para ello. No se aconseja limpiar el arma con cepillos de alambre, ya que el interior del cañón podría sufrir daños.

Las piezas metálicas exteriores se deberán frotar de vez en cuando con un trapo ligeramente impregnado de aceite para armas y las bisagras del cañón deben lubricarse con regularidad.

¡Atención! No almacene la carabina de aire comprimido con el resorte del pistón tensado. El resorte del pistón podría fatigarse y mermar la capacidad de disparo del arma.

Tacos de limpieza, artículo n° 3.2055

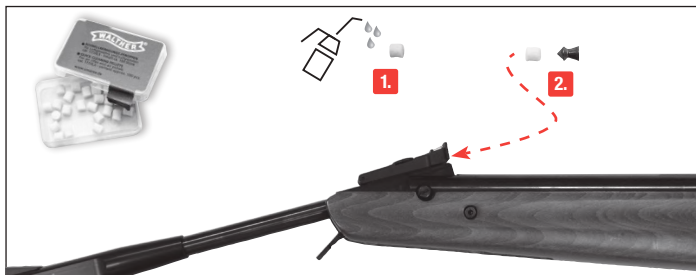

Varillas de limpieza, artículo n°. cal. 4,5 mm / cal. 5,5 mm 3.2054

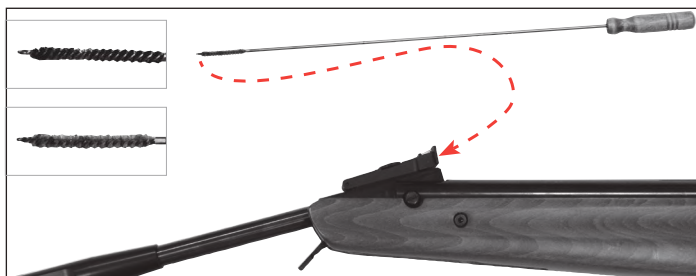

ACCESORIOS Y PROBLEMAS

Gatillo tuning de metal
600.110



Silenciador de 3 cámaras
2.4849



Grasa Walther para resortes, 10ml
3.2061



Lubricante para pistones Walther, 30ml
3.2060



PROBLEMAS

POSIBLES MOTIVOS

PROBLEMAS	Seguro activado	Cañón sucio	Munición inadecuada	Munición mal cargada	Vuelva a doblar el cañón. Deberá oírse un clic cuando encaje el pistón.	Desactive el seguro y accione el gatillo. Compruebe el ajuste del peso del gatillo en el tornillo trasero.
Potencia de disparo deficiente		●	●	●		
El arma no dispara	●		●	●	●	
Baja velocidad de disparo		●	●	●		
El arma no se puede amartillar. No encaja.						●



CARRILLERA

ES



La carrillera del modelo Competition-Ultra se puede ajustar en altura con los dos tornillos al lado derecho.





ES



SILENCIADOR

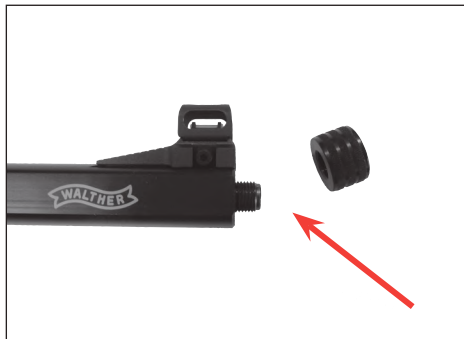

Para colocar el silenciador hay que quitar primero la tuerca del cañón.
Después se podrá atornillar el silenciador.





WALTHER LGV

The Sound of Silence.



AIR RIFLE · LUFTGEWEHR · CARABINE À AIR COMPRIMÉ · CARABINA DE AIRE COMPRIMIDO
FUCILE AD ARIAN COMPRESSA · ПНЕВМАТИЧЕСКАЯ ВИНТОВКА · BROŃ PNEUMATYCZNA · HAVALI TÜFEK
cal. 4,5 mm (.177)
cal. 5,5 mm (.22)

EN Operating instructions 2 - 11 | DE Bedienungsanleitung 12 - 22 | FR Mode d'emploi 23 - 33 | ES Instrucciones de uso 34 - 44
IT Istruzioni per l'uso 45 - 55 | RU Инструкция по эксплуатации 56 - 66 | PL Instrukcja obsługi 67 - 77 | TR Kullanım Kilavuzu 78 - 88



VIBRATION
REDUCTION
SYSTEM



SUPER
SILENT
TECHNOLOGY



UTILIZZO SICURO DELLE ARMI AD ARIA COMPRESSA

IT



DESCRIZIONE



UTILIZZO



MANUTENZIONE



NORME DI SICUREZZA

È molto importante essere assolutamente certi di quello che si fa quando si maneggia un'arma. Nell'ottica delle norme di base per un utilizzo sicuro delle armi ad aria compressa, ricordate sempre che toccare un'arma, significa contemporaneamente maneggiarla.

- Trattate l'arma sempre come se fosse carica.
- Quando caricate l'arma, attivate sempre la sicura per evitare che involontariamente parta un colpo. Tenete il dito sempre al di fuori del ponticello, fino all'attimo prima di sparare.
- Utilizzate solo i proiettili indicati per quest'arma.
- Indirizzate l'arma sempre in una direzione sicura.
- Il tiro è ammesso soltanto all'interno della propria abitazione, in poligoni abilitati dalle autorità di polizia e su terreni che non possano essere oltrepassati dal proiettile. Considerate la portata massima del proiettile.
- Non trasportate mai un'arma carica. Caricatela soltanto se volete sparare.
- Non indirizzate mai l'arma verso persone o animali. Controllate che il proiettile non possa rimbalzare. Non sparate mai su superfici lisce, dure o sull'acqua.
- Accertatevi prima di sparare della sicurezza del bersaglio e delle sue immediate vicinanze.
- Controllate sempre se l'arma è scarica prima di trasportarla o prima di prenderla in consegna da un'altra persona.
- Tenete l'arma in modo da poterne controllare la direzione della volata anche se inciampate o state cadendo.
- Per motivi di sicurezza consigliamo di portare occhiali di protezione durante il tiro.
- Conservate e riponete al sicuro l'arma sempre scarica e al di fuori dalla portata di persone non autorizzate (inesperti, bambini) e separata dalle munizioni.
- Affidate quest'arma, insieme con le istruzioni d'uso, esclusivamente a persone
 - che hanno perfetta dimestichezza con il maneggio di quest'arma, e
 - che hanno raggiunto l'età minima legale secondo la legge sulle armi in vigore nel vostro paese.
- Qualsiasi modifica o riparazione dell'arma deve essere effettuata esclusivamente da ditte o armaioli specializzati.
- Non lasciate mai incustodita l'arma carica.
- Scaricate la vostra arma prima di consegnarla ad altre persone.

GARANZIA

Entro un anno dalla data di acquisto, la ditta Umarex procede gratuitamente alla riparazione o sostituzione dell'arma, a condizione che il difetto non sia imputabile all'utilizzatore. Affidate l'arma ad un rivenditore autorizzato, descrivete il problema e consegnate la prova di acquisto.

Le armi ad aria compressa prodotte dalla ditta UMAREX GmbH & Co. KG vengono costruite in conformità ai requisiti di certificazione dell'Ente federale fisico-tecnico (Physikalisch-Technische Bundesanstalt PTB), alle leggi federali, alla normativa CIP e in base al know how acquisito dalla ditta UMAREX GmbH & Co. KG nella fabbricazione di armi sportive.

In caso di esportazione all'estero, il produttore declina qualsiasi responsabilità per la non conformità dell'arma alle norme vigenti nel paese di destinazione nonché per eventuali difficoltà giuridiche e le relative conseguenze che ne potrebbero risultare per il proprietario/l'acquirente.

**IT****NORME DI SICUREZZA****DESCRIZIONE****ATTENZIONE**

Per la vostra e per l'altrui sicurezza, leggete attentamente e completamente le istruzioni di montaggio prima di usare l'arma per la prima volta. L'acquirente ed il detentore dell'arma hanno l'obbligo di seguire tutte le regole vigenti per il possesso e l'utilizzo delle armi ad aria compressa. Qualsiasi modifica apportata all'arma è inammissibile in quanto può comportare una variazione della classificazione secondo le norme vigenti sul possesso delle armi. In questo caso la garanzia del produttore decade con effetto immediato.

RIPARAZIONE

Un'arma che non funziona perfettamente è pericolosa. È molto difficile riparare autonomamente un'arma, e un assemblaggio non corretto può determinare pericolosi malfunzionamenti.

Attenzione:

Fate controllare e riparare l'arma esclusivamente da un rivenditore/armaiolo autorizzato.

SPECIFICHE TECNICHE

Sistema	Fucile ad aria compressa / Canna basculante								
Fonte d'energia	Pistone a molla								
Sicura	Automatica								
Grilletto	grilletto Match regolabile (precorsa e forza di sgancio)								
Numero di colpi	1 diabolino (monocolpo)								
Lunghezza della canna	450 mm								
Lunghezza totale	1095 mm								
Larghezza totale	54 mm								

Modello	Challenger / Challenger Ultra			Master / Master Ultra			Competition Ultra		
Calibro	4,5mm	4,5mm	5,5mm	4,5mm	4,5mm	5,5mm	4,5mm	4,5mm	5,5mm
Energia	7.5 J	23 J	16 J	7.5 J	23 J	16 J	7.5 J	23 J	16 J
Velocità del proiettile	175m/s	295m/s	175m/s	175m/s	295m/s	175m/s	175m/s	295m/s	175m/s
Peso	3,8 kg			4,2 kg			4,4 kg		
Calcio	Calcio di plastica			Calcio di legno			Calcio di legno		

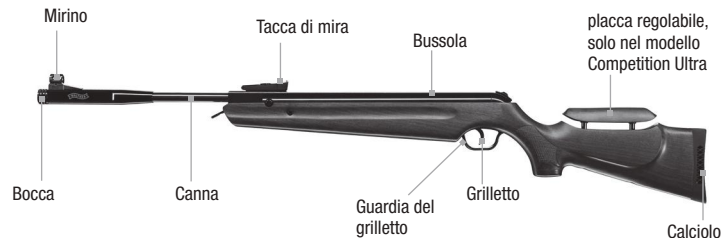
**SICURA**

Il fucile ha una sicura del grilletto, la quale assicura automaticamente la vostra arma in ogni processo di armamento. Per togliere la sicura spostare la leva di sicurezza nella posizione anteriore. Vedere figure!

**ATTENZIONE**

Maneggiate l'arma solo quando la sicura è attivata. Badate sempre a che la bocca dell'arma sia orientata in una direzione sicura.



SICURA



SAFE

FIRE

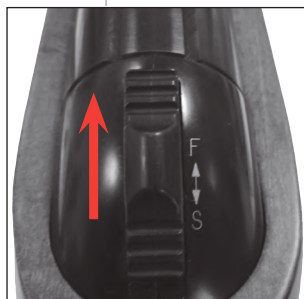

REGOLAZIONE DEL GRILLETTO TUNING DI METALLO

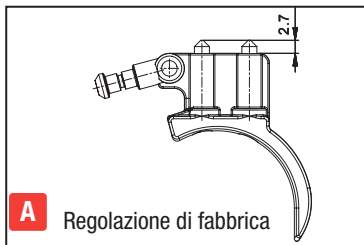

Regolazione di fabbrica

Nella condizione in cui viene fornita l'arma il grilletto presenta una regolazione standard (figura A). Regolate sempre soltanto una vite e verificate il funzionamento e la conseguenza. Avvitando la vite si riducono forza e corsa. Svitando si allungano le corse e aumentano le forze di scancio.



REGOLAZIONE DEL GRILLETTO STANDARD

IT



1 Regolazione della precorsa

2 Regolazione della precorsa

La precorsa, vale a dire la corsa della linguetta del grilletto fino al punto di resistenza, è regolabile individualmente.

Il peso di sgancio può essere regolato individualmente, in modo continuo. Ruotando la vite 2 verso destra (senso orario), il peso di sgancio aumenta. Ruotando la vite 2 verso sinistra (senso antiorario), il peso di sgancio diminuisce. Vedere figure!

Regolazione della precorsa

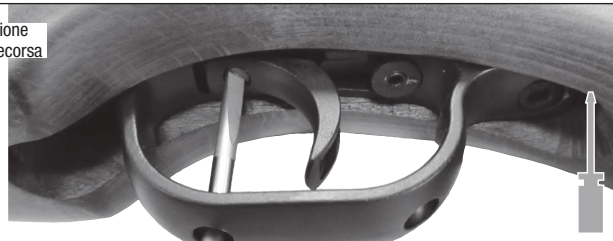

Regolazione del peso di scancio

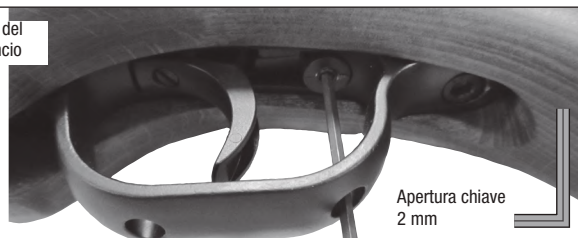



IT



ARMAMENTO E CARICAMENTO

ATTENZIONE

- Non lasciare il fucile ad aria compressa con la molla del pistone armata per molto tempo. Ciò può condurre a incidenti e inoltre può affaticare la molla del pistone, danneggiando così il rendimento di tiro dell'arma.
- Non sparare a secco (senza proiettile). Esiste il pericolo di danneggiare l'arma.

NOTA:

Una volta armata l'arma è messa in sicurezza automaticamente.

Per armare azionate la leva di sbloccaggio della canna e ribaltate la canna verso il basso fino a che il grilletto scatta in posizione in modo udibile. Il diavolo viene caricato all'estremità posteriore della canna. Vedere figure! Non utilizzate mai diavolo difettosi o deformati.

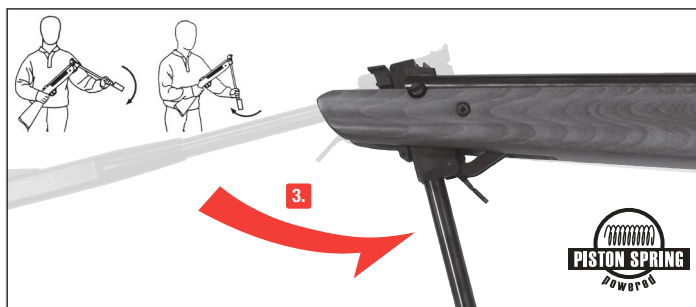
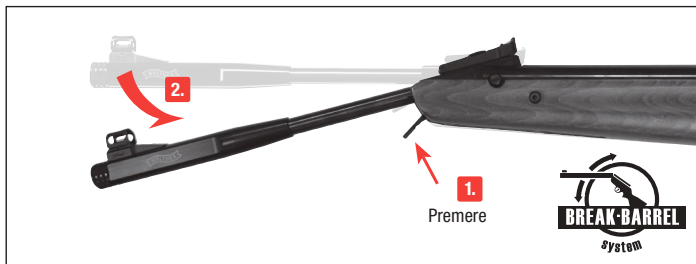

ATTENZIONE

Attenzione! Quando armate e caricate tenete sempre saldamente la canna con una mano. Non azionate mai il grilletto quando la canna è ripiegata. La canna salirebbe di colpo verso l'alto, piegandosi ed eventualmente provocando ferimenti! Il risultato sarebbe la crepatura o rottura del calcio. **In questo caso decade ogni garanzia.**

Non sparate con proiettili non idonei, come ad es. piumini. Per fucili ad aria compressa con canna rigata sono idonei soltanto diavolo con calibro adeguato.

Riportate la canna nella propria posizione di partenza. Il fucile è ora pronto al fuoco e con sicura inserita.





PUNTAMENTO

IT

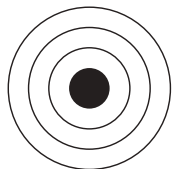

Ideale

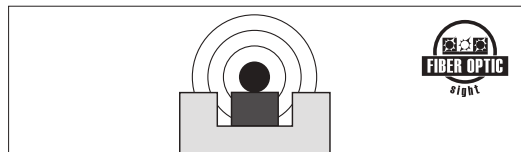

Errato

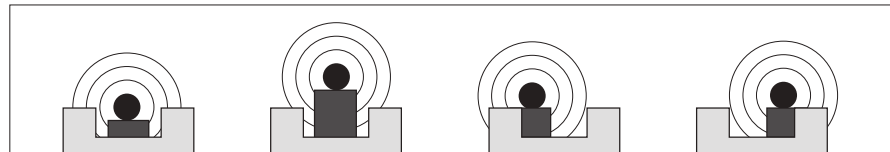

REGOLAZIONE DEL DISPOSITIVO DI MIRA



La tacca di mira del vostro fucile ad aria compressa è regolabile lateralmente e in altezza. Vedere figure!

La fornitura comprende differenti fogliette della tacca di mira. Una volta rimossa la vite della tacca di mira anteriore è possibile sostituire le fogliette.

REGOLAZIONE LATERALE

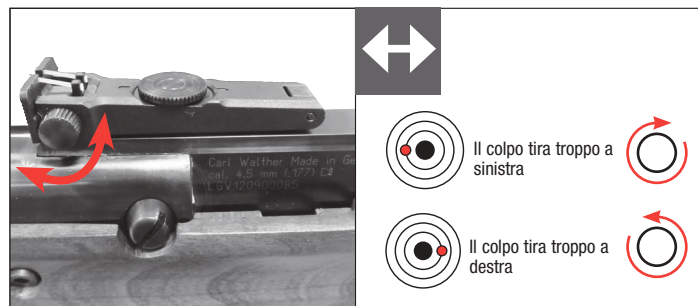

REGOLAZIONE IN ALTEZZA

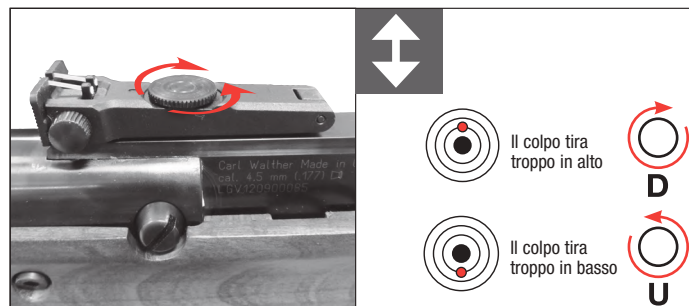



ATTENZIONE

- Maneggiate l'arma solo quando la sicura è attivata.
- Badate sempre a che la bocca dell'arma sia orientata in una direzione sicura.
- Trattandosi di un'arma high-energy, usate soltanto bersagli non penetrabili dal proiettile.

Attenzione! Sparare con l'arma scarica deve essere evitato, dato che il colpo d'urto in avanti, non frenato, conduce a una sollecitazione molto elevata del fucile.



Quando si spara con fucili con pistone a molla bisogna prestare attenzione al fatto che il fucile non venga tenuto troppo saldamente nell'arresto. Anche differenti tipi di diavolo danno risultati differenti.

Assicuratevi prima di sparare che l'obiettivo e l'area circostante siano sicuri. Quindi tirate il grilletto con tranquillità. Una volta tirato il grilletto rimanete ancora alcuni secondi sul bersaglio. Tenete presente che una modifica dell'arresto varia il punto di impatto.

Attenzione! Non portate le vostre mani a contatto con viso e bocca, quando avete maneggiato proiettili di fucili ad aria. Lavatevi accuratamente le mani per rimuovere le particelle di piombo.

Disarmamento e scaricamento

Nel caso abbiate comunque deciso di non sparare, agite come segue:

Per scaricare l'arma innanzi tutto disarmatela. A questo scopo ripiegate la canna fino alla posizione di arresto posteriore e tenetela saldamente con una mano, togliete la sicura del fucile e azionate il grilletto.

ATTENZIONE: tenere saldamente la canna!

Quindi conducete la canna lentamente nella sua posizione di partenza.

Per disarmare il fucile aprite la canna, senza armare la molla del pistone e con uno scovolo spingete il diavolo fuori dalla canna.

Non azionate mai il grilletto quando il fucile è armato e la canna è ripiegata (eccezione – disarmamento, ved. sopra). La canna salirebbe di colpo verso l'alto, piegandosi ed eventualmente provocando ferimenti! Il pistone urta sulla tiranteria dell'asta e può rompersi. Può anche verificarsi una crepatura o una rottura dei calci. **In questo caso decade ogni garanzia.**

Non azionare mai il grilletto quando il fucile è piegato (eccezione – disarmamento, ved. sopra).

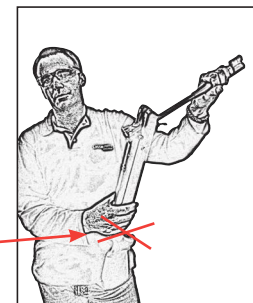



PULIZIA DELLA CANNA E MANUTENZIONE GENERALE

Assicuratevi che il Vostro fucile sia disarmato e scarico.

A intervalli regolari la canna va pulita con i mezzi ausiliari destinati allo scopo. Si sconsiglia di utilizzare per la pulizia spazzole metalliche, le quali potrebbero danneggiare l'interno della canna. Parti metalliche esterne vanno strofinate di quando in quando con un panno imbevuto di olio per armi e le cerniere sulla canna vanno oliate leggermente con regolarità.

Attenzione! Non riponete il vostro fucile ad aria compressa con la molla del pistone armata. La molla del pistone potrebbe affaticarsi, riducendo così il rendimento di tiro dell'arma.

Tappo di pulizia, articolo n. 3.2055

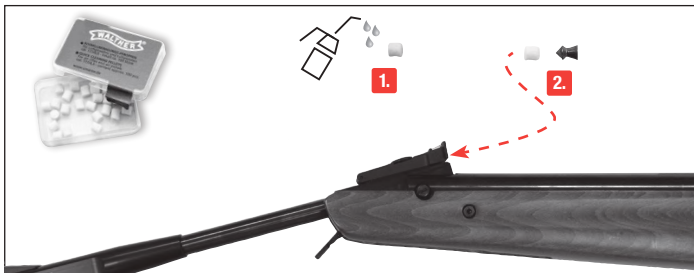

Barra di pulizia, articolo n. cal. 4,5 mm / cal. 5,5 mm 3.2054

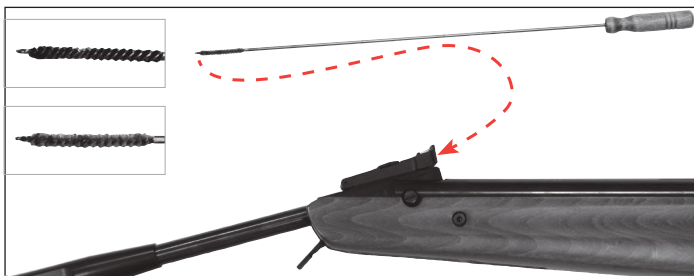

ACCESSORI E PROBLEMI

IT

Grilletto Tuning in metallo
2.4849



Silenziatore a 3 camere
2.4849



Grasso Walther per molle, 10ml
3.2061



Grasso per pistone Walther, 30ml
3.2060



PROBLEMI

POSSIBILI CAUSE

PROBLEMI	Sicura inserita	Canna sporca	Munizioni sbagliate	Munizioni caricate in modo errato	Ripiegare nuovamente la canna, fino a che il pistone non si innesta in modo udibile	Togliere la sicura e azionare il grilletto. Verificare le regolazioni della forza di sgancio sulla vite posteriore.
Scarsa precisione		●	●	●		
L'arma non spara	●		●	●	●	
Velocità ridotta del proiettile		●	●	●		
Non è possibile armare l'arma. Non si innesta.						●



IT



PLACCA POGGIA GUANCIA



Con le due viti sul lato destro è possibile regolare in altezza la placca poggia guancia del modello Competition-Ultra.





SILENZIATORE

IT

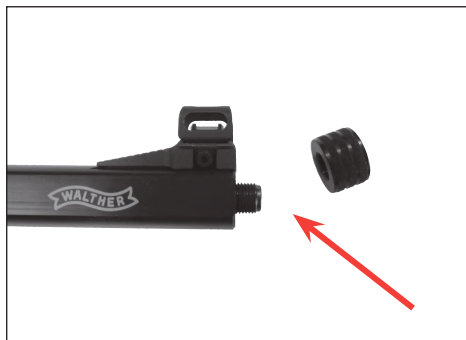

Per applicare il silenziatore, è necessario prima rimuovere il dado della canna. Successivamente è possibile avvitare in posizione il silenziatore.



WALTHER

WALTHER LGV

The Sound of Silence.



[V]
VIBRATION
REDUCTION
SYSTEM

[S]
SUPER
SILENT
TECHNOLOGY

AIR RIFLE · LUFTGEWEHR · CARABINE À AIR COMPRIMÉ · CARABINA DE AIRE COMPRIMIDO
FUCILE AD ARIAN COMPRESSA · ПНЕВМАТИЧЕСКАЯ ВИНТОВКА · BROŃ PNEUMATYCZNA · HAVALI TÜFEK
cal. 4,5 mm (.177)
cal. 5,5 mm (.22)

EN Operating instructions 2 - 11 | DE Bedienungsanleitung 12 - 22 | FR Mode d'emploi 23 - 33 | ES Instrucciones de uso 34 - 44
IT Istruzioni per l'uso 45 - 55 | RU Инструкция по эксплуатации 56 - 66 | PL Instrukcja obsługi 67 - 77 | TR Kullanım Kilavuzu 78 - 88



Лучшие в исполнении - винтовки Walther для спорта и досуга.

Название Walther тесно связано с разработкой инновационных пневматических винтовок. Чемпионы олимпийских игр, мира и Европы, восхищенные спортсмены-любители во всем мире доверяют „Best Performance“ (оптимальным параметрам) этого совершенного до мельчайших деталей стрелкового оружия. Фирма Carl Walther относится сегодня к ведущим изготовителям пневматических винтовок для спорта и досуга.

История успеха началась в 50-ые и 60-ые годы 20-го столетия. За это время стрельба из пневматического оружия развилась в массовый спорт. Этому содействовала и первая разработанная Фритцом Вальтером пружинно-поршневая винтовка, модели Walther LG 51. С помощью чемпионской пневматической винтовки LG 55 M команда Швейцарии выиграла золотые медали на чемпионате мира в 1966 г. Притязание на повышение точности фирма Walther претворила в жизнь в 1964 г. — винтовкой модели Walther LGV.





БЕЗОПАСНОЕ ОБРАЩЕНИЕ С ОРУЖИЕМ



Наименование



Техническое обслуживание



Уход



Указания по технике безопасности

Необходимо знать, как правильно и безопасно обращаться с оружием. С точки зрения основных правил безопасной стрельбы помните, что обращением является любое прикосновение к оружию.

- Обращайтесь с любым оружием так, как если бы оно было заряжено.
- При заряджании всегда ставьте оружие на предохранитель во избежание непроизвольного выстрела. Никогда не держите палец на спусковом крючке; класть палец на спусковой крючок только для производства выстрела.
- Используйте только предусмотренные для этого оружия пули.
- Всегда держите ствол оружия в безопасном направлении.
- Стрельба разрешается только в собственной квартире, на стрельбищах, имеющих официальное разрешение полиции, а также на обнесенных забором владениях, если пуля при выстреле не покинет их пределы. При этом необходимо учитывать зону случайного поражения пули.
- Транспортировка оружия в заряженном состоянии строго запрещена. Всегда заряжайте его непосредственно перед выстрелом.
- Никогда не направляйте оружие на людей или животных. Избегайте рикошета. Никогда не стреляйте в гладкие, твердые поверхности, а также на водную поверхность.
- Перед выстрелом убедитесь в безопасности цели и выстрела для окружающих.
- Всегда проверяйте, чтобы оружие не было заряжено при транспортировке или если принимаете его от другого лица.
- Убедитесь в том, что Вы способны контролировать направление ствола оружия при падении или если споткнетесь.
- В целях безопасности при стрельбе необходимо надевать защитные очки.
- Всегда храните оружие в разряженном виде и на предохранителе, отдельно от патронов, в местах, недоступных посторонним (лицам, не обученным специально, детям, лицам до 18 лет).
- Передача этого оружия возможна только вместе с инструкцией по эксплуатации и только лицам, которые в точности знают, как обращаться с этим оружием, и которые имеют соответствующий минимальный возраст согласно закону об оружии в соответствующей стране.
- Любые изменения в конструкции оружия или его ремонт должны производиться только в специализированных фирмах или оружейным мастером.
- Никогда не выпускайте из рук заряженного оружия.
- Передача оружия другому лицу возможна, только если оружие разряжено.

ГАРАНТИЯ

Фирма Umagex бесплатно осуществит ремонт или замену оружия в течение установленного законом периода времени со дня покупки, если неисправность возникла не по вине владельца. Передайте оружие продавцу, имеющему соответствующую лицензию, опишите проблему и приложите документ, подтверждающий покупку. Пневматическое оружие производства фирмы UMAREX GmbH & Co. KG изготавливается в соответствии с правилами Федерального физико-технического института (PTB), регламентирующими допуск к эксплуатации, федеральным законом, нормами CIP и оружейно-техническим ноу-хау фирмы UMAREX GmbH & Co. KG. Таким образом, мы не несём ответственности за экспортированное за границу оружие, если оно не соответствует действующим в этой стране нормативным актам, или при возникновении у владельца /покупателя трудностей юридического характера, повлекших за собой соответствующие последствия.



УКАЗАНИЯ ПО ТЕХНИКЕ БЕЗОПАСНОСТИ



ВНИМАНИЕ

В целях Вашей собственной безопасности и безопасности других внимательно прочтите всю инструкцию по эксплуатации, прежде чем предпринять первую попытку производства выстрела. Покупатель и владелец оружия обязаны соблюдать все правила пользования и владения пневматическим оружием. Любое изменение конструкции этого оружия может привести к изменению категории оружия и потому недопустимо. В этом случае гарантийные обязательства производителя автоматически теряют силу.

РЕМОНТ

Оружие, у которого механизмы не работают исправно, является опасным. Сложно самостоятельно ремонтировать оружие, и его неправильная сборка может привести к опасным отказам.

Внимание:

Отдавайте оружие на проверку и ремонт только в специализированные магазины / оружейным мастерам.

ТЕХНИЧЕСКИЕ ДАННЫЕ

Система	пневматическая винтовка / переламывающийся ствол				
Источник энергии	поршень-пружина				
Предохранитель	автоматический				
Спусковой крючок	регулируемый спусковой механизм (предварительный ход и усилие спуска)				
Количество выстрелов	1 пуля Diabolo (1-зарядная)				
Длина ствола	450 mm				
Общая длина	1095 mm				
Общая ширина	54 mm				

Модель	Challenger / Challenger Ultra			Master / Master Ultra			Competition Ultra		
Калибр	4,5mm	4,5mm	5,5mm	4,5mm	4,5mm	5,5mm	4,5mm	4,5mm	5,5mm
Энергия	7.5 J	23 J	16 J	7.5 J	23 J	16 J	7.5 J	23 J	16 J
Скорость полета пули	175m/s	295m/s	175m/s	175m/s	295m/s	175m/s	175m/s	295m/s	175m/s
Вес	3,8 kg			4,2 kg			4,4 kg		
Приклад	пластиковый приклад			деревянный приклад			деревянный приклад		



НАИМЕНОВАНИЕ

RU



ПРЕДОХРАНИТЕЛЬ

У винтовки имеется предохранитель спуска, который автоматически ставит Ваше оружие на предохранитель при каждом взводе боевой пружины. Для снятия с предохранителя передвиньте рычаг предохранителя в переднее положение. Смотри рисунки!



ВНИМАНИЕ

Обращайтесь с оружием только в том случае, если оно стоит на предохранителе. Всегда следите за тем, чтобы ствол оружия был направлен в безопасную сторону.



RU ПРЕДОХРАНИТЕЛЬ

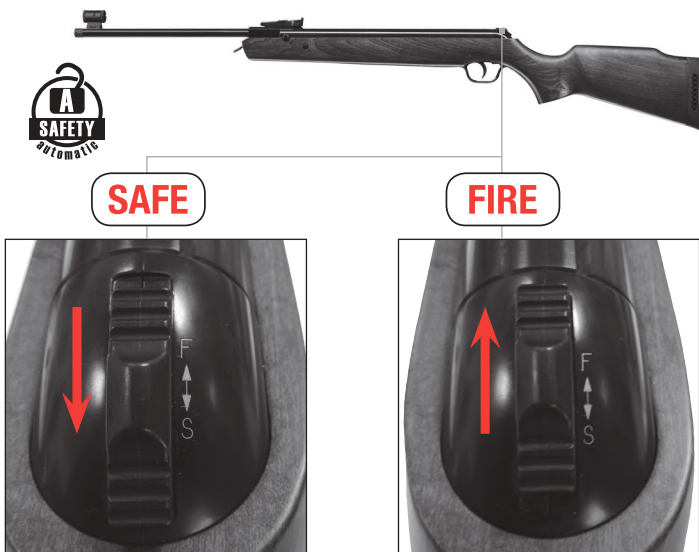

SAFE

FIRE

НАСТРОЙКА ТЮНИНГОВАННОГО СПУСКОВОГО КРЮЧКА ИЗ МЕТАЛЛА

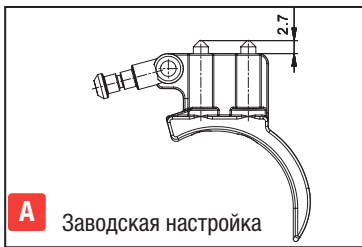

A Заводская настройка

В состоянии поставки спусковой крючок имеет стандартную настройку (рис. А). Изменяйте настройку только с помощью одного винта и проверяйте работу и результат. При вворачивании винта усилие и путь уменьшаются. При выворачивании удлиняется путь и увеличивается усилие спуска.

НАСТРОЙКА СТАНДАРТНОГО СПУСКОВОГО КРЮЧКА



1 Настройка предварительного хода

2 Настройка усилия спуска

Имеется возможность индивидуальной настройки предварительного хода, т. е. хода хвоста спускового крючка до положения спуска.

Усилие спуска регулируется индивидуально и бесступенчато. Вращением винта 2 вправо (по часовой стрелке) усилие спуска повышается. Вращением винта влево (против часовой стрелки) усилие спуска уменьшается. Смотри рисунки!

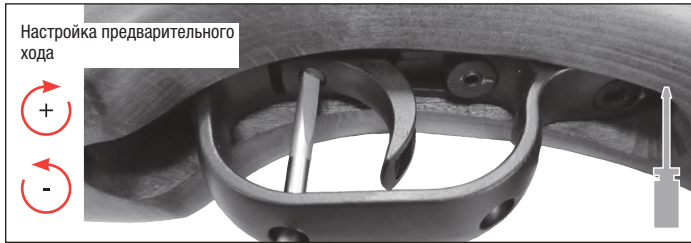

Настройка предварительного хода



Настройка усилия спуска

Размер ключа 2 мм



ВЗВОД И ЗАРЯЖАНИЕ

RU

⚠ ВНИМАНИЕ

- Не оставляйте пневматическую винтовку на длительное время со взведенной пружиной поршня. Это может привести к несчастным случаям и кроме того пружина поршня может испытать усталость, что отрицательно сказывается на результатах выстрела оружия.
- Не производить выстрелы вхолостую (без пули). Существует опасность повреждения оружия.

УКАЗАНИЕ:

После взвода оружие автоматически ставится на предохранитель.

Для взвода приведите в действие рычаг разблокировки ствола и переломите ствол вниз, чтобы спусковой крючок зафиксировался со слышимым щелчком. Пуля Diabolo заряжается на заднем конце ствола. Смотри рисунок!

Никогда не используйте дефектные или деформированные пули Diabolo.

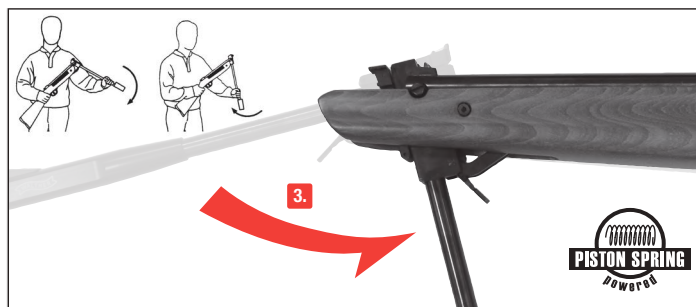
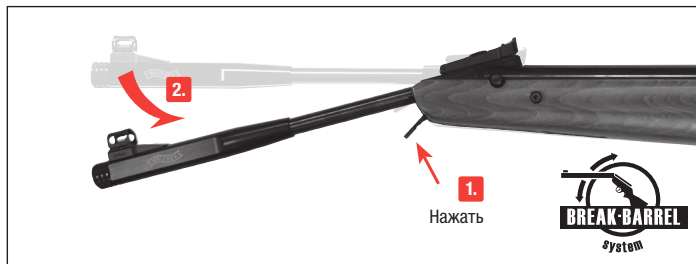

⚠ ВНИМАНИЕ

Внимание! При взводе и зарядании всегда одной рукой удерживайте ствол. Никогда не нажимайте на спусковой крючок, когда ствол переломлен. Ствол в этом случае отпружинит вверх, деформируется и может привести к травмам! Результатом может быть трещина или поломка приклада. **В таком случае гарантия теряет силу.**

Не стреляйте непригодными пулями, как, например, ударные пружинные бойки. Для пневматических винтовок с нарезным стволом пригодны только пули Diabolo подходящего калибра.

Верните ствол назад в его исходное положение. Винтовка готова к выстрелу и стоит на предохранителе.





RU ПРИЦЕЛИВАНИЕ

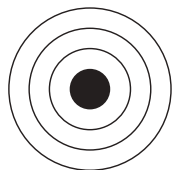

Идеально

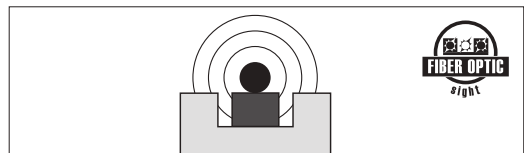

Не правильно

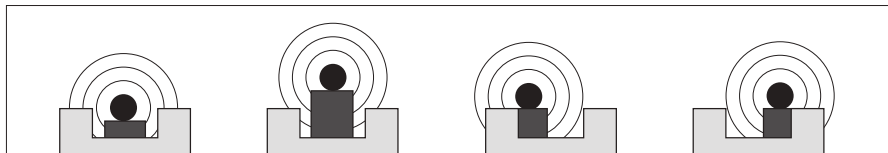

УСТАНОВКА ПРИЦЕЛЬНОГО ПРИСПОСОБЛЕНИЯ

Открытая прицельная планка Вашей пневматической винтовки регулируется в боковом направлении и по высоте. Смотри рисунки!

В объем поставки входят различные сменные мушки. После удаления винта мушки Вы можете заменить мушку.



РЕГУЛИРОВКА В БОКОВОМ НАПРАВЛЕНИИ

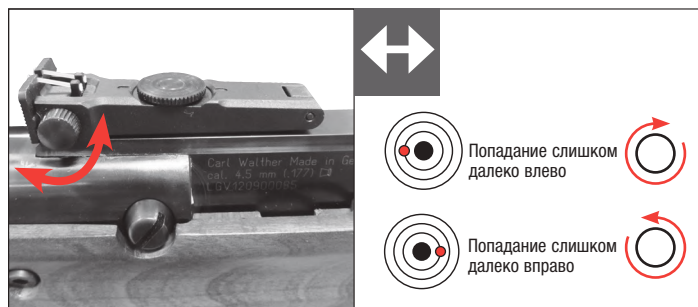

РЕГУЛИРОВКА ПО ВЫСОТЕ

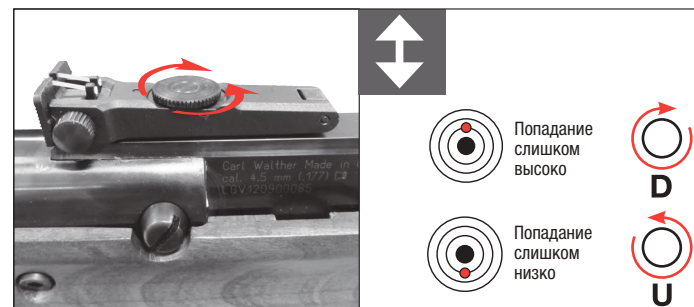



ПРОИЗВОДСТВО ВЫСТРЕЛА

RU

⚠ ВНИМАНИЕ

- Обращайтесь с оружием только в том случае, если оно стоит на предохранителе.
- Всегда следите за тем, чтобы ствол оружия был направлен в безопасную сторону.
- В связи с высокой энергией оружия используйте только цели, которые пуля не пробьет насквозь.

Внимание! Следует избегать выстрелов из незаряженного оружия, так как беспрепятственный сильный удар ведет к очень высокой нагрузке на винтовку.



При стрельбе из пружинно-поршневой винтовки необходимо учитывать, что винтовку не следует удерживать слишком крепко в упоре. Следствием станут неточные выстрелы. И различные виды пуль Diabolo дают различные результаты. Перед выстрелом убедитесь в безопасности цели и выстрела для окружающих. Затем спокойно спустите спусковой крючок. После спуска оставайтесь еще несколько секунд на мишени. Учитывайте, что изменение упора изменяет положение попаданий.

Внимание! Избегайте контакта Ваших рук с лицом и ртом, когда у Вас в руках были пули для пневматической винтовки. Тщательно вымойте Ваши руки, чтобы удалить частицы свинца.

Снятие со взвода и разряжение

Если Вы все же решили не производить выстрел, действуйте следующим образом:

Для разряжения сначала снимите оружие с боевого взвода. Для этого переломите ствол до заднего фиксированного положения и крепко удерживайте одной рукой ствол, снимите Вашу винтовку с предохранителя и нажмите на спусковой крючок.

ВНИМАНИЕ: Надежно удерживайте ствол!

Затем отведите ствол медленно в его исходное положение.

Для разряжения откройте ствол, не взводя пружину поршня, и выдавите пулю Diabolo из ствола с помощью шомпола.

Никогда не нажимайте на спусковой крючок, когда винтовка взведена и ствол переломлен (исключение – снятие со взвода, см. выше). Ствол в этом случае отпружинит вверх, деформируется и может привести к травмам! Поршень удалит по рычажному механизму и может сломаться. Может также произойти трещина или поломка приклада.

В таком случае гарантия теряет силу.

Никогда не нажимайте на спусковой крючок при переломленной винтовке (исключение – снятие со взвода, см. выше).

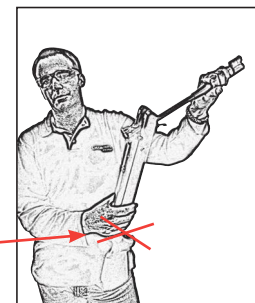



ЧИСТКА СТВОЛА И УХОД

Удостоверьтесь, что Ваша винтовка не взведена и не заряжена.
Через регулярные промежутки времени необходимо чистить ствол с помощью предусмотренных для этого вспомогательных средств. Не рекомендуется чистить проволочными щетками, так как ствол может быть поврежден внутри. Внешние металлические детали необходимо время от времени протирать тканью, слегка смоченной в ружейном масле, а шарниры на стволе необходимо регулярно легко смазывать маслом.

Внимание! Не храните Вашу пневматическую винтовку со взведенной пружиной поршня. Пружина поршня может испытать усталость, что отрицательно сказывается на показателях стрельбы.

Чистящий тампон, изделие № 3.2055

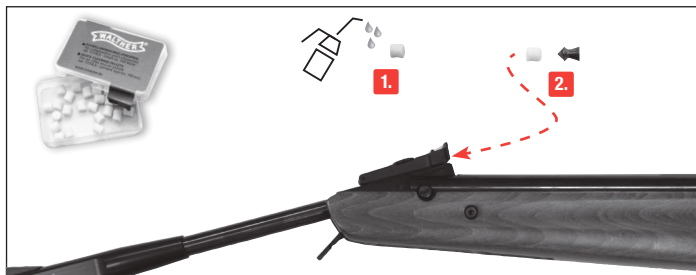

Шомпол, изделие № кал. 4,5 мм / кал. 5,5 мм 3.2054

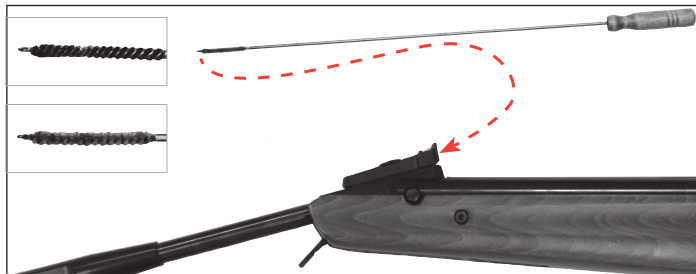

ПРИНАДЛЕЖНОСТИ И ПРОБЛЕМЫ

Тюнинг-ованный спусковой крючок из металла 600.110



3-камерный глушитель 2.4849



Смазка Walther для пружин, 10 мл 3.2061



Смазка Walther для поршня, 30 мл 3.2060



ПРОБЛЕМЫ

ВОЗМОЖНЫЕ ПРИЧИНЫ

ПРОБЛЕМЫ	оружие стоит на предохранителе	ствол загрязнен	боеприпасы не подходят	боеприпасы неправильно заряжены	Еще раз переломить ствол, пока поршень не защелкнется со слышимым щелчком	Снять с предохранителя и нажать на спусковой крючок. Проверить настройки усилия спуска на заднем винте.
плохие показатели стрельбы		●	●	●		
оружие не стреляет	●		●	●	●	
низкая скорость полета пули		●	●	●		
Оружие не удается взвести. Не защелкивается.						●



ЩЕКА ПРИКЛАДА

RU

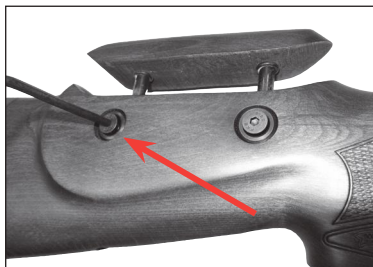

С помощью двух винтов на правой стороне можно регулировать щеку приклада модели Competition-Ultra по высоте.





RU



ГЛУШИТЕЛЬ

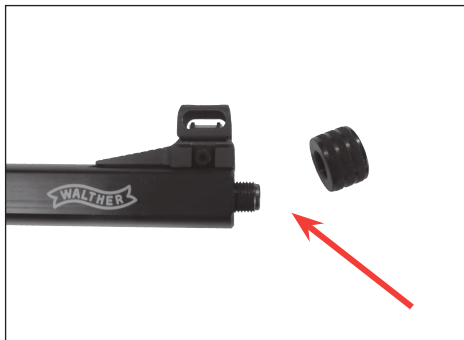

Чтобы разместить глушитель, необходимо сначала удалить гайку ствола. Затем можно привинтить глушитель.





WALTHER LGV

The Sound of Silence.



AIR RIFLE · LUFTGEWEHR · CARABINE À AIR COMPRIMÉ · CARABINA DE AIRE COMPRIMIDO
FUCILE AD ARIAN COMPRESSA · ПНЕВМАТИЧЕСКАЯ ВИНТОВКА · BROŃ PNEUMATYCZNA · HAVALI TÜFEK
cal. 4,5 mm (.177)
cal. 5,5 mm (.22)

EN Operating instructions 2 - 11 | DE Bedienungsanleitung 12 - 22 | FR Mode d'emploi 23 - 33 | ES Instrucciones de uso 34 - 44
IT Istruzioni per l'uso 45 - 55 | RU Инструкция по эксплуатации 56 - 66 | PL Instrukcja obsługi 67 - 77 | TR Kullanım Kilavuzu 78 - 88



VIBRATION
REDUCTION
SYSTEM



SUPER
SILENT
TECHNOLOGY



Best Performance - Broń Walther do zastosowań sportowych i rekreacyjnych

Nazwa Walther jest ściśle powiązana z rozwojem innowacyjnej broni pneumatycznej. Olimpicy zwycięzcy, mistrzowie świata i Europy, zapaleni strzelcy z klubów strzelckich i strzelcy niezrzeszeni z całego świata ufają „Best Performance” tej dopracowanej w najdrobniejszych szczegółach długiej broni. Carl Walther należy obecnie do wiodących producentów broni pneumatycznej przeznaczonej do zastosowań sportowych i rekreacyjnych.

Historia sukcesu rozpoczęła się w latach 50-tych i 60-tych XX wieku. W tym czasie strzelanie z broni pneumatycznej przerodziło się w masowy sport. Przyczyniła się do tego również pierwsza zaprojektowana przez Fritza Walthera broń z tłokiem sprężynowym, Walther LG 51. Z mistrzowską bronią pneumatyczną LG 55 M drużyna ze Szwajcarii zdobyła złote medale na mistrzostwach świata w roku 1966. Dążenie do zwiększenia precyzji Walther przeobraził w czyn w roku 1964 – opracowując broń Walther LGV.



BEZPIECZNE OBCHODZENIE SIĘ Z BRONIĄ

PL



NAZWA



OBSŁUGA



PIELĘGNACJA



WSKAZÓWKI BEZPIECZEŃSTWA

Należy zapoznać się z odpowiednim, bezpiecznym sposobem postępowania z bronią. W związku z podstawowymi zasadami bezpiecznego strzelania proszę pamiętać, że każde dotknięcie broni jest uważane za jej obsługę.

- Proszę postępować z bronią tak, jakby była naładowana.
- Podczas ładowania broni należy ją zabezpieczać, aby nie było możliwości przypadkowego oddania strzału. Należy zawsze trzymać palce poza pałąkiem spustu, palec na spust należy kłaść tylko w celu oddania strzału.
- Należy stosować wyłącznie naboje przeznaczone dla tej broni.
- Wylot lufy należy zawsze trzymać w bezpiecznym kierunku.
- Strzelanie jest dozwolone tylko we własnym mieszkaniu, na stanowiskach strzeleckich dopuszczonych przez policję oraz na terenach chronionych, jeżeli pocisk nie może podczas strzału opuścić tego terenu. Przestrzegać obszaru zagrożenia pocisku.
- Nigdy nie transportować załadowanej broni. Broń wolno ładować tylko wówczas, gdy ma zostać oddany strzał.
- Nie wolno kierować broni w stronę ludzi lub zwierząt. Należy unikać strzałów parabolicznych. Nie wolno strzelać w kierunku gładkich, twardych powierzchni lub na powierzchnie wody.
- Przed oddaniem strzału należy się upewnić, że cel i obszar otoczenia są bezpieczne.
- Należy zawsze kontrolować, czy broń nie jest załadowana, gdy jest ona transportowana lub przejmowana przez inną osobę.
- Należy się upewnić, że jesteś w stanie kontrolować kierunek wylotu również w przypadku potknięcia lub upadku.
- Ze względów bezpieczeństwa należy podczas strzelania nosić okulary ochronne.
- Broń należy przechowywać zawsze w bezpieczny sposób, nie załadowaną, zabezpieczoną przed niedozwolonym dostępem (nieprzeszkolonych osób, dzieci, osób poniżej 18 roku życia) i oddzielnie od amunicji.
- Przekazywanie tej broni wraz z instrukcją obsługi jest dozwolone tylko osobom, które dokładnie znają sposób obsługi tej broni i które posiadają odpowiedni wiek zgodnie z przepisami obowiązującymi w danym kraju.
- Wszelkiego rodzaju zmiany lub naprawy broni powinny być wykonywane przez wyspecjalizowane firmy lub przez rusznikarza.
- Nie wolno nigdy wypuszczać załadowanej broni z ręki.
- Innym osobom wolno przekazywać wyłącznie rozładowaną broń!

GWARANCJA

W ustawowym okresie gwarancyjnym liczonym od daty zakupu Firma Umarex gwarantuje bezpłatną naprawę lub wymianę broni, o ile usterka nie została zawiniona przez użytkownika. Broń należy oddać w autoryzowanym punkcie sprzedaży, opisać problem i dołączyć dowód zakupu.

Broń pneumatyczna firmy UMAREX GmbH & Co. KG produkowana jest zgodnie z przepisami Federalnego Urzędu Fizyczno-Technicznego (PTB), niemieckiego ustawodawstwa, przepisami CIP oraz wiedzą techniczną firmy UMAREX GmbH & Co. KG na temat broni.

Tym samym w przypadku eksportu towaru za granicę nie odpowiadamy za ewentualne problemy prawne właściciela/nabywcy wynikające z niezgodności towaru z przepisami obowiązującymi w danym kraju.

**PL****WSKAZÓWKI BEZPIECZEŃSTWA****NAZWA****UWAGA**

Dla własnego bezpieczeństwa i dla bezpieczeństwa innych osób należy przeczytać w całości i starannie instrukcję obsługi przed rozpoczęciem pierwszych prób strzelania z broni. Nabywca i właściciel mają obowiązek przestrzegania wszystkich reguł związanych z eksploatacją i posiadaniem broni pneumatycznej. Każde zmiany przeprowadzane na tej broni mogą prowadzić do zmiany klasyfikacji prawnej broni, w związku z czym są one niedozwolone. W takim przypadku następuje natychmiastowe wygaśnięcie gwarancji producenta.

NAPRAWA

Broń, która nie działa prawidłowo, jest niebezpieczna. Samodzielna naprawa broni jest trudna, a nieprawidłowe jej złożenie może prowadzić do niebezpiecznych usterek w działaniu.

Uwaga:

Broń może być sprawdzana i naprawiana tylko przez autoryzowanego sprzedawcę / ruszniarza.

DANE TECHNICZNE

System	Broń pneumatyczna / łamana								
Źródło energii	Sprężyna tłokowa								
Bezpiecznik	Automatyczny								
Spust	regulowany spust Match (droga spustu i siła zwalniania)								
Ilość strzałów	1 Diabolo (1-strzałowy)								
Długość lufy	450 mm								
Długość całkowita	1095 mm								
Szerokość całkowita	54 mm								

Model	Challenger / Challenger Ultra			Master / Master Ultra			Competition Ultra		
Kaliber	4,5mm	4,5mm	5,5mm	4,5mm	4,5mm	5,5mm	4,5mm	4,5mm	5,5mm
Energia	7.5 J	23 J	16 J	7.5 J	23 J	16 J	7.5 J	23 J	16 J
Prędkość pocisku	175m/s	295m/s	175m/s	175m/s	295m/s	175m/s	175m/s	295m/s	175m/s
Waga	3,8 kg			4,2 kg			4,4 kg		
Kolba	Kolba z tworzywa			Kolba drewniana			Kolba drewniana		

**BEZPIECZNIK**

Broń jest wyposażona w bezpiecznik spustu, który zabezpiecza automatycznie broń przy każdym procesie naciągania. W celu odbezpieczenia przesunąć dźwignię blokującą do przodu. Patrz ilustracje!

**UWAGA**

Manipulację bronią są możliwe tylko wówczas, gdy jest ona zabezpieczona. Należy zawsze zwracać uwagę, aby wylot lufy był zwrócony w bezpiecznym kierunku.



BEZPIECZNIK



SAFE



FIRE



REGULACJA SPUSTU METAL-TUNING

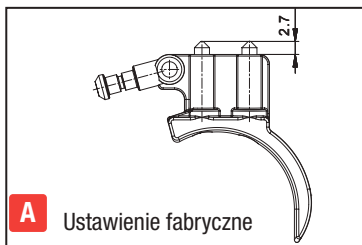

A Ustawienie fabryczne

Podczas dostawy spust jest ustawiony standardowo (ilustracja A). Należy przestawiać zawsze tylko jedną śrubę i przetestować funkcję i działanie. Wkręcanie śruby powoduje zmniejszenie siły i dróg. Wykręcanie powoduje wydłużenie dróg i zwiększenie sił zwalniania spustu.



REGULACJA SPUSTU STANDARD

PL



1 Ustawianie drogi spustu

Droga spustu, tzn. droga języczka spustu do punktu nacisku, jest regulowana indywidualnie.

2 Ustawianie oporu spustu

Opór spustu jest regulowany indywidualnie i bezstopniowo. Poprzez obrót śruby 2 w prawo (zgodnie z ruchem wskazówek zegara) zwiększamy opór spustu. Poprzez obrót śruby w lewo (przeciwnie do ruchu wskazówek zegara) zmniejszamy opór spustu. Patrz ilustracje!

Ustawianie drogi spustu

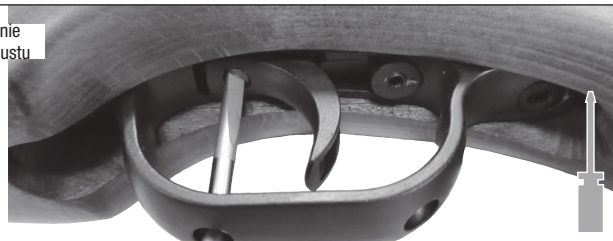

Ustawianie oporu spustu





NACIĄGANIE I ŁADOWANIE

UWAGA

- Nie wolno pozostawiać broni pneumatycznej przez dłuższy czas z naciągniętą sprężyną tłokową. Może to prowadzić do wypadków, a oprócz tego powoduje zmęczenie sprężyny tłoka, przez co zmniejsza się wydajność strzelania broni.
- Nie strzelać pustą bronią (bez pocisku). Istnieje niebezpieczeństwo uszkodzenia broni!

UWAGA:

Po naciągnięciu broń jest automatycznie zabezpieczona.

W celu naciągnięcia zwolnic dźwignię odblokowania lufy i odchylić lufę w dół do momentu słyszalnego zatrzaśnięcia spustu. Śrut diabło jest ładowany na tylnym końcu lufy.

Patrz ilustracja!

Nie wolno stosować wadliwego lub zdeformowanego śrutu diabła.

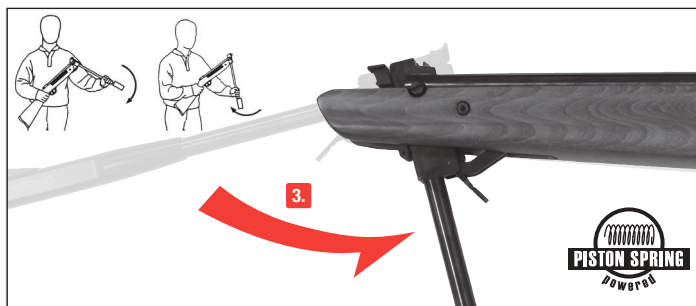
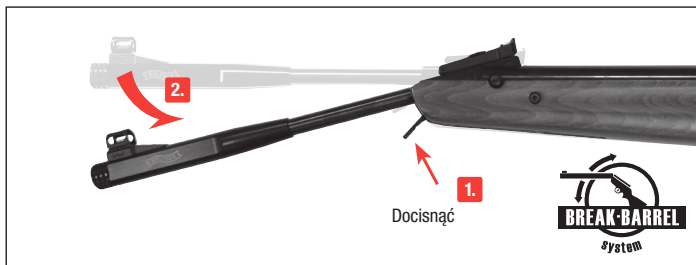

UWAGA

Uwaga! Podczas naciągnięcia i ładowania należy zawsze trzymać jedną ręką lufę. Nie wolno uruchamiać spustu, gdy lufa jest złamana. Lufa odskoczy wówczas w górę, nastąpi jej wygięcie, co może spowodować obrażenia! Skutkiem tego będzie pęknięte lub złamane łożo. **Nastąpi wygaśnięcie gwarancji.**

Nie wolno strzelać za pomocą nieodpowiednich nabojów, np. strzałkami. Dla broni pneumatycznej z łamaną lufą nadaje się wyłącznie śrut o odpowiednim kalibrze.

Odprowadzić lufę w jej położenie wyjściowe. Broń jest teraz gotowa do strzału i zabezpieczona.





CELOWANIE

PL

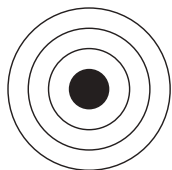

Idealne

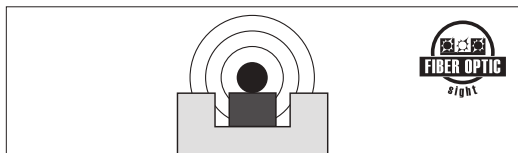

Nieprawidłowo

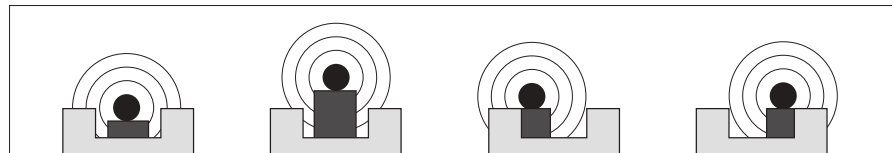

USTAWIANIE WIZJERA



Szczerbinka otwartego wizjera broni pneumatycznej jest regulowana w bok i na wysokość. Patrz ilustracje!

W komplecie znajdują się różne rodzaje muszki. Po odkręceniu śruby muszki można dokonać wymiany muszki.

REGULACJA BOCZNA

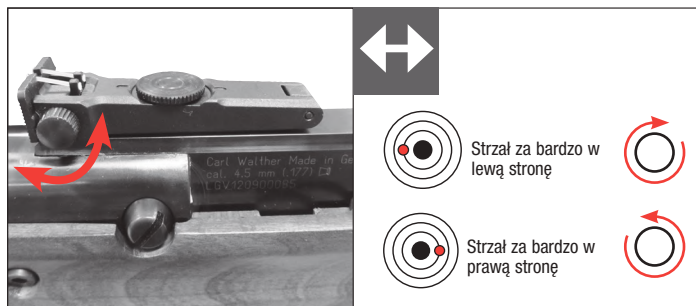

REGULACJA WYSOKOŚCI

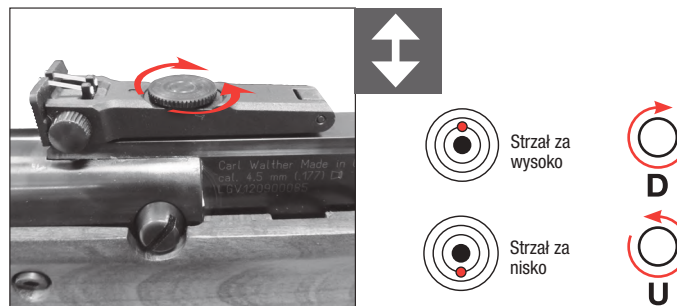

**UWAGA**

- Manipulacje bronią są możliwe tylko wówczas, gdy jest ona zabezpieczona.
- Należy zawsze zwracać uwagę, aby wylot lufy był zwrócony w bezpiecznym kierunku.
- Ze względu na dużą energię broni należy stosować tylko cele, które nie mogą zostać przebite przez pociski.

Uwaga! Należy unikać strzelania niezaladowaną bronią, ponieważ niewyhamowane uderzenie prowadzi do bardzo dużego obciążenia broni.



Podczas strzelania z broni z tłokiem sprężynowym należy uważać, aby nie trzymać broni ze zbyt dużym oporem. Następstwem jest niedokładne strzelanie. Również różne rodzaje śrutów powodują osiągnięcie różnych wyników.

Przed oddaniem strzału należy się upewnić, że cel i obszar otoczenia są bezpieczne.

Następnie spokojnie nacisnąć spust. Po zwolnieniu spustu należy jeszcze przez kilka sekund celować w tarczę.

Proszę pamiętać, że zmiana ogranicznika powoduje zmianę punktu celowania.

Uwaga! Należy unikać kontaktu rąk z twarzą i ustami, gdy wcześniej trzymałeś w rękach amunicję broni pneumatycznej. Należy dokładnie umyć ręce celem usunięcia cząsteczek ołowiu.

Zwalnianie i rozładowanie

W przypadku rezygnacji z oddania strzału należy postępować w następujący sposób:

Aby rozładować należy najpierw zwolnić spust broni. W tym celu należy złamać lufę aż do tylnej pozycji zaczepiania, przytrzymać mocno lufę jedną ręką, odbezpieczyć broń i nacisnąć spust.

UWAGA: Należy mocno trzymać lufę!

Następnie powoli odprowadzić lufę w jej położenie wyjściowe.

Aby rozładować należy otworzyć lufę bez naciągania sprężyny tłokowej i wypchnąć śrut z lufy za pomocą wycioru.

Nie wolno naciskać spustu, gdy broń jest naciągnięta, a lufa jest złamana (wyjątek – zwalnianie, p.w.). Lufa odskoczy wówczas w górę, nastąpi jej wygięcie, co może spowodować obrażenia! Tłok uderzy w zespół dźwigni spustu i może się złamać. Może również dojść do zerwania lub pęknięcia łoża.

Nastąpi wygaśnięcie gwarancji.

Przy złamanej broni nie wolno naciskać spustu (wyjątek – zwalnianie, p.w.).





CZYSZCZENIE I KONSERWACJA LUFY

Należy się upewnić, czy broń jest nie naciągnięta i nie naładowana. Należy regularnie czyścić lufę za pomocą przeznaczonych do tego środków. Nie zaleca się czyszczenia za pomocą szczotki drucianej ze względu na możliwość uszkodzenia wnętrza lufy.

Zewnętrzne metalowe części należy od czasu do czasu przetrzeć szmatką nasączoną lekkim olejem do broni oraz należy regularnie lekko oliwić zawiasy na lufie.

Uwaga! Nie wolno przechowywać broni pneumatycznej z napiętą sprężyną tłokową. Sprężyna tłokowa może ulec zmęczeniu, co spowoduje zmniejszenie wydajności strzelania.

Tłok do czyszczenia, art. nr 3.2055

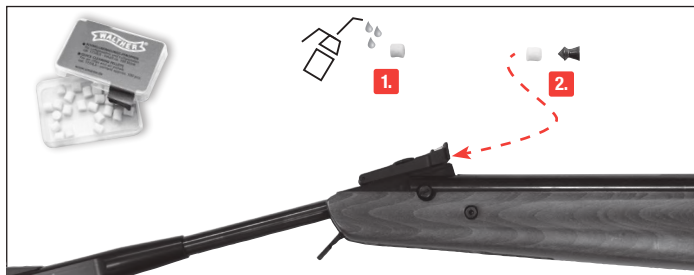

Pręt do czyszczenia, art. nr kal. 4,5 mm / kal. 5,5 mm 3.2054

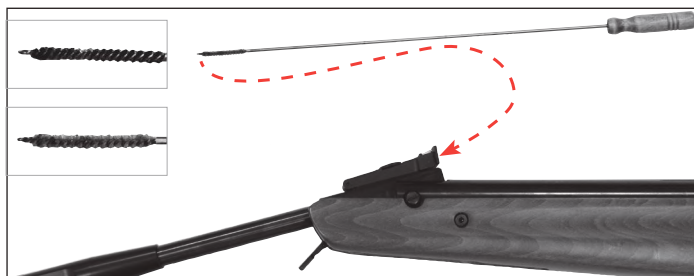

AKCESORIA I PROBLEMY

PL

Spust Tuning z metalu
600.110



Tłumik 3-komorowy
2.4849



Smar Walther do sprężyn, 10ml
3.2061

Smar Walther, 30ml
3.2060



PROBLEMY

MOŻLIWE PRZYCZYNY

PROBLEMY	Broń zabezpieczona	Zamieczyszczona lufa	Nieprawidłowa amunicja	Amunicja nieprawidłowo załadowana	Ponownie złamać lufę aż do słyszalnego zablokowania tłoka	Odbezpieczyć i nacisnąć spust. Sprawdzić ustawienia siły zwalniania spustu na tylniej śrubie.
Słaba wydajność strzelania		●	●	●		
Broń nie strzela	●		●	●	●	
Mała prędkość pocisku		●	●	●		
Broni nie da się napiąć. Nie blokuje się.						●



PL



PODPÓRKA RĘKOJEŃCI

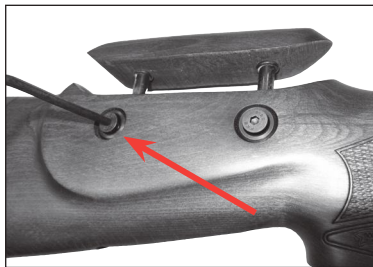

Za pomocą obu śrub z prawej strony można regulować podpórkę rękojeści modelu Competiti-on-Ultra na wysokość.

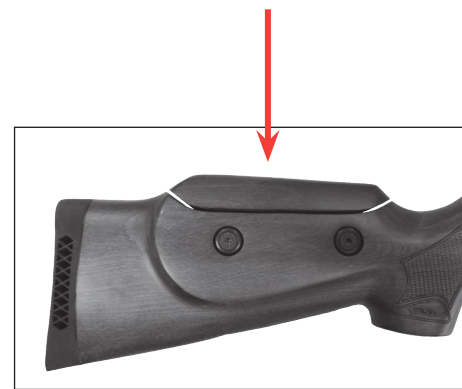



TŁUMIK

PL

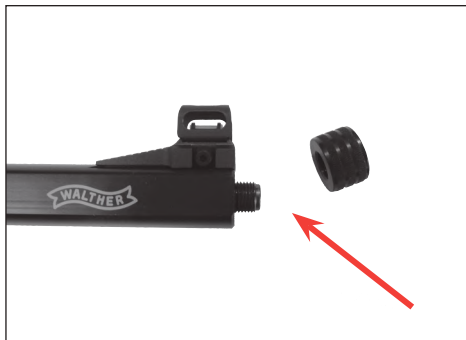

Aby założyć tłumik należy najpierw odkręcić nakrętkę lufy.
Następnie można przykręcić tłumik.



WALTHER

WALTHER LGV

The Sound of Silence.



[V]

VIBRATION
REDUCTION
SYSTEM

[S]

SUPER
SILENT
TECHNOLOGY

AIR RIFLE · LUFTGEWEHR · CARABINE À AIR COMPRIMÉ · CARABINA DE AIRE COMPRIMIDO
FUCILE AD ARIAN COMPRESSA · ПНЕВМАТИЧЕСКАЯ ВИНТОВКА · BROŃ PNEUMATYCZNA · HAVALI TÜFEK
cal. 4,5 mm (.177)
cal. 5,5 mm (.22)

EN Operating instructions 2 - 11 | DE Bedienungsanleitung 12 - 22 | FR Mode d'emploi 23 - 33 | ES Instrucciones de uso 34 - 44
IT Istruzioni per l'uso 45 - 55 | RU Инструкция по эксплуатации 56 - 66 | PL Instrukcja obsługi 67 - 77 | TR Kullanım Kilavuzu 78 - 88



En İyi Performans – Spor ve eğlence amaçlı WALTHER havalı tüfekleri.

Yenilikçi havalı tüfeklerin geliştirilmesi konusu, Walther ismi olmadan düşünülemez. Olimpiyat şampiyonları, dünya ve Avrupa şampiyonları, dünyanın dört bir yanındaki atıcılık kulüplerinin üyeleri ve atıcılık meraklıları, tasarımı en küçük ayrıntılarına kadar olgunlaşmış uzun silahların "Best Performance" (En İyi Performans) özelliğine güvenirlir. Carl Walther firması, günümüzde spor ve eğlence amaçlı havalı tüfeklerin lider üreticileri arasındadır.

Walther'in başarı öyküsü 20. yüzyılın 50'li ve 60'lı yıllarında başladı. Bu dönemde basınçlı hava kullanan silahlarla ateş etmek yaygın bir halk sporu haline geldi. Buna, Fritz Walther tarafından geliştirilen ilk yaylı pistonlu tüfek Walther LG 51 de katkıda bulundu. 1966 yılı dünya şampiyonasında İsviçre atıcılık takımı, havalı tüfek LG 55 M ile dünya şampiyonluğunu kazandı. Hassasiyeti daha da artırma iddiasını gerçeğe dönüştürmek üzere Walther firması 1964 yılında Walther LGV'yi geliştirdi.





SİLAHLARIN GÜVENLİ KULLANIMI



PARÇALARIN ADLARI



KULLANIM



BAKIM



GÜVENLİK BİLGİLERİ

Silahınızın doğru ve güvenli şekilde kullanımına vakf olmanız gerekmektedir. Güvenli silah atmanın ana kuralları açısından, silah ile her türlü temas kullanım olarak anlaşıldığı göz önünde bulundurun.

- Her silaha, sanki dolu imiş gibi muamele edin.
- Silahı doldurma esnasında her zaman, yanlışlıkla ateş alamayacağı şekilde emniyete alın. Parmağınızı her zaman tetik koruyucusunun dışında tutun ve sadece ateşlemek için tetiğin üzerine koyun.
- Sadece, bu silahla kullanılması öngörülen mühimmatı kullanın.
- Namluyu her zaman emniyetli bir yöne tutun.
- Sadece kendi evinizde, polis tarafından izin verilen atış poligonlarında ve çit veya duvarlarla çevrili bir mülk içerisinde, merminin bu alanın dışına çıkamayacağı koşullarda atış yapılabilir. Merminin tehlike menziline hesaba katın.
- Hiçbir zaman silahı dolu olarak taşımayın. Silahı sadece atış yapmak istediğiniz zaman doldurun.
- Silahı hiçbir zaman insanların veya hayvanların üzerine doğrultmayın. Kurşunların sekmeyeceği şekilde ateş etmeye dikkat edin. Hiçbir zaman kaygan, sert yüzeylere veya su yüzeylerine ateş etmeyin.
- Atış yapmadan önce hedefin ve çevredeki alanın güven altında olduğundan emin olun.
- Silahı taşımadan önce veya başka birinden teslim aldıktan hemen sonra, dolu olup olmadığını kontrol edin.
- Tökezlemeniz veya düşmeniz halinde bile namlunun yönünü kontrol edebileceğinizden emin olun.
- Emniyet açısından atış sırasında koruyucu gözlük kullanılmalıdır.
- Silahı daima boş olarak ve emniyetli halde, mühimattan ayrı olarak ve yetkisz kişilerin (eğitimi ve deneyimi olmayanların, 18 yaşın altında kişilerin) izinsiz erişemeyeceği şekilde saklayın.
- Bu silahı kullanım kılavuzu ile beraber sadece
- bu silahın kullanımına çok iyi vakif olan ve
- bulunduğunuz ülkenin silah mevzuatı uyarınca gereken 18 yaşından büyük ve kişilere verebilirsiniz.
- Silahların üzerinde yapılacak her türlü değişiklik veya tamirat sadece uzman şirketler veya silah ustası tarafından yapılmalıdır.
- Hiçbir zaman dolu bir silahı elden bırakmayın.
- Sadece boşaltılmış silahları başka kişilere verin.

GARANTİ

Satış tarihinden sonraki bir yıl içerisinde, silahta oluşan arıza kendi hatanızdan dolayı oluşmamış ise, Umarex şirketi silahınızı ücretsiz olarak tamir eder veya karşılığında yenisini verir. Silahı yetkili bir satıcıya götürün, ana sorunu anlatın ve satış belgesini sunun.

Umarex şirketi tarafından üretilen havali silahlar, Fizik ve Teknik ile ilgili Federal Daire'nin (PTB) ruhsatlandırma şartlarına, federal yasaya, CIP talimatlarına ve de Umarex şirketinin silah teknoloji konusundaki deneyimlerine dayanılarak üretilmektedir.

Bu sebeple, eğer bu silah yurt dışına ihraç edildikten sonra o ülkenin hükümlerine uymadığı tespit edilirse ve sahibi/alıcısı bundan dolayı hukuki sorunlarla ve bunların sonuçları ile karşılaşrsa, şirketimiz herhangi bir mesuliyet kabul etmemektedir.



GÜVENLİK BİLGİLERİ



DİKKAT

Hem kendinizin hem de başkalarının emniyeti için, silah ile ilk atış denemesine kalkışmadan önce, bu kullanım kılavuzunu tam olarak ve itina ile okuyun. Bu silahları satın alan veya sahibi olan kişiler, havalı silahların kullanılması ve bulundurulması ile ilgili tüm kurallara uymakla yükümlüdürler. Bu silah üzerinde yapılacak her türlü değişiklik silah mevzuatına göre yapılan sınıflandırmanın değişmesine neden olabilir ve bu sebeple yasaktır. Üreticinin verdiği olduğu garanti bu durumda geçerliliğini derhal kaybeder.

TAMİR

Kusursuz çalışmayan bir silah tehlikelidir. Bir silahı kendi başınıza tamir etmeniz zordur ve yanlış monte edilmesi tehlikeli fonksiyon anzarlarına neden olabilir.

Dikkat:

Silahınızı sadece yetkili bir uzman satıcı/silah ustası tarafından kontrol ve tamir ettirin.

TEKNİK ÖZELLİKLER

Sistem	Havali tüfek / Kırmalı								
Enerji kaynağı	Yaylı piston								
Emniyet	Otomatik								
Tetik	ayarlanabilir Match tetikleme (tetik hareketi ve tetik sertliği)								
Atış sayısı	1 Diabolo (1 atımlı)								
Namlu uzunluğu	450 mm								
Toplam uzunluk	1095 mm								
Toplam genişlik	54 mm								
Toplam yükseklik	200 mm								

Model	Challenger / Challenger Ultra			Master / Master Ultra			Competition Ultra		
Kalibre	4,5mm	4,5mm	5,5mm	4,5mm	4,5mm	5,5mm	4,5mm	4,5mm	5,5mm
Enerji	7.5 J	23 J	16 J	7.5 J	23 J	16 J	7.5 J	23 J	16 J
Mermi hızı	175m/s	295m/s	175m/s	175m/s	295m/s	175m/s	175m/s	295m/s	175m/s
Ağırlık	3,8 kg			4,2 kg			4,4 kg		
Kundak	Plastik kundak			Tahta kundak			Tahta kundak		



PARÇALARIN ADLARI

TR



EMNİYET

Tüfeğin, her kurma işleminde silahınızı otomatik olarak emniyete alan bir tetik emniyeti vardır. Emniyeti çözmek için emniyet mandalını ön pozisyona itin. Bkz. şekiller!



DİKKAT

Silahu sadece, emniyetsiz halde iken elinize alın. Namlunun her zaman güvenli bir yöne doğrultulmuş olduğuna dikkat edin.



TR



EMNİYET



STANDART TETİK AYARI

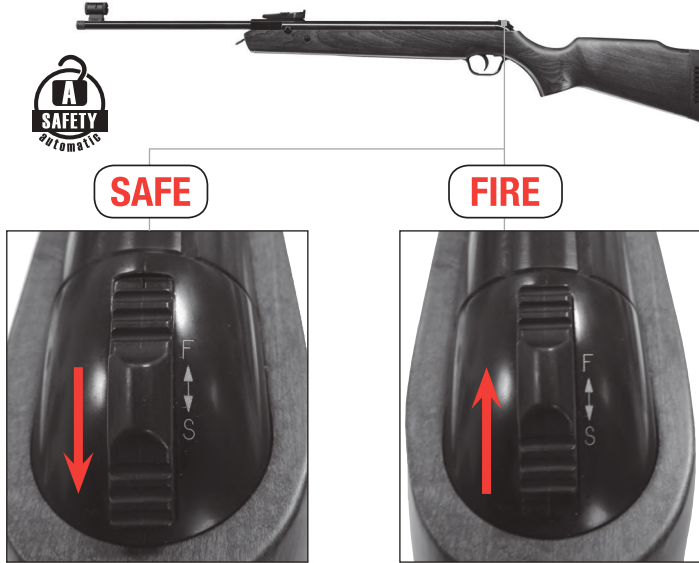

SAFE

FIRE



METAL -TUNING - TETİK AYARI

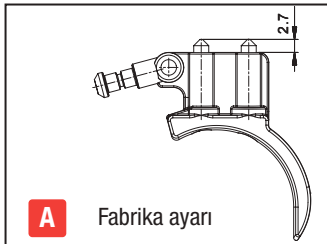

A

Fabrika ayarı

Fabrika çıkışı olarak tetik standart olarak ayarlanmıştır (Şekil A). Her defasında sadece bir vida ayarını değiştirin ve fonksiyonu ve etkiyi test edin. Vida içeri gömülecek şekilde döndürüldüğünde tetik sertliği ve hareket yolu azalır. Vida dışarı döndürüldüğünde hareket yolu uzar ve tetik sertliği artar.



1 Tetik hareketi ayarı

Tetik hareketi, yani tetik kolunun basınç noktasına kadarki hareket yolu, kişisel isteğe göre ayarlanabilir.

2 Tetik sertlik ayarı

Tetik sertliği kişisel isteğe göre ve kademesiz olarak ayarlanabilir. Vida 2 sağa (saat yönünde) döndürülerek tetik sertliği artırılır. Vida sola (saatin tersi yönde) döndürülerek sertlik azaltılır. Bkz. Şekiller!

Tetik hareketi ayarı



Tetik sertlik ayarı

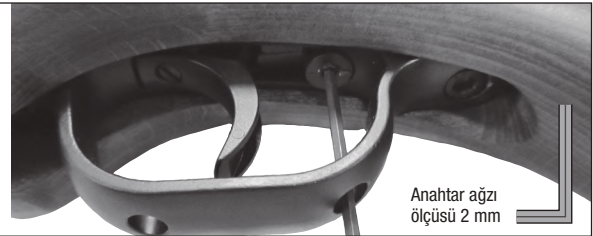

Anahtar ağı ölçüsü 2 mm



KURMAK VE DOLDURMAK

TR

⚠ DİKKAT

- Havalı tüfeği uzun süre, yaylı pistonu gergin durumda bırakmayın. Bu, kazalara yol açabilir ve ayrıca yaylı pistonda oluşabilir, bunun sonucunda da silahın atış performansı zarar görür.
- Silahı boş (içinde mermi olmadan) ateşlemeyin. Silahın zarar görmesi tehlikesi vardır.

UYARI:

Kurulduktan sonra silah otomatik olarak emniyete alınır.

Kurmak için namlu gevşetme mandalına bastırın ve namluyu, tetik ses çıkararak tırnağa oturuncaya kadar aşağı bükün.

Diabolo namlunun içine arka ucundan sürülür.

Bkz. şekil!

Hiçbir zaman defolu veya deforme olmuş Diabolo kullanmayın.

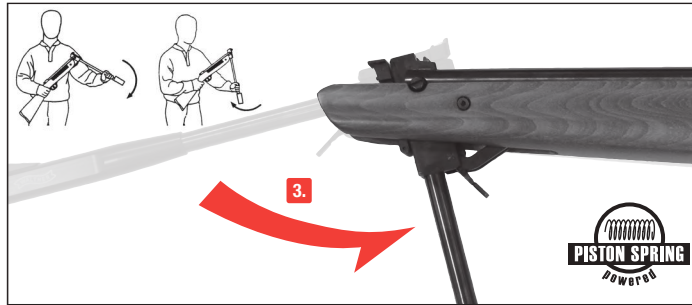
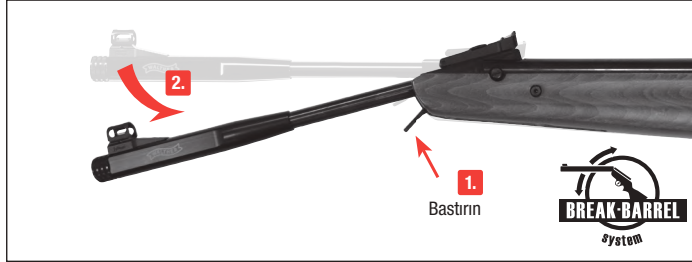

⚠ DİKKAT

Dikkat! Kurarken ve doldururken her zaman bir elinizle namluyu sıkıca tutun. Namlu aşağı bükülmüş haldeyken kesinlikle tetiğe basmayın. Aksi halde namlu yukarı teper, eğrilir ve yaralanmalara neden olabilir! Bunun sonucunda kundak çatlayabilir ya da kırılabilir. **Böyle bir durumda her türlü garanti geçersiz hale gelir.**

Dikkat! Uygun olmayan mühimmat, örn. yaylı saplama, kullanmayın. Yıvli namlusu olan havalı tüfekler için sadece uygun kalibreli Diabololar elverişlidir.

Namluyu başlangıç pozisyonuna geri götürün. Tüfek artık atışa hazır ve emniyetlidir.

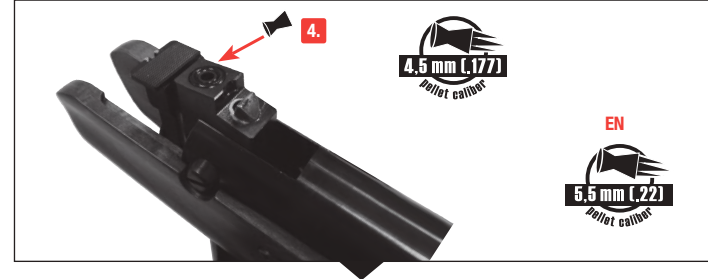



TR



NİŞAN ALMAK

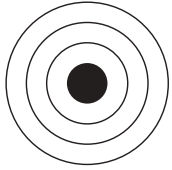

İdeal durum

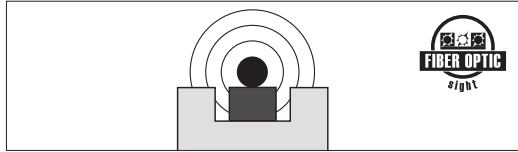

Yanlış

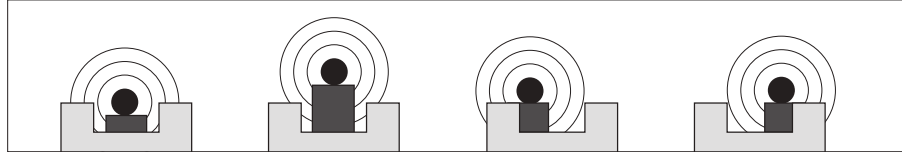

NİŞANGÂH AYARI

Havali tüfeğinizin açık nişangâhının gezi, sola-sağa ve aşağı-yukarı ayarlanabilir.

Ürün ambalajında çeşitli arpacık yapıları bulunmaktadır. Arpacık vidasını söktükten sonra arpacık yaprağını değiştirebilirsiniz



SOL-SAĞ AYARI

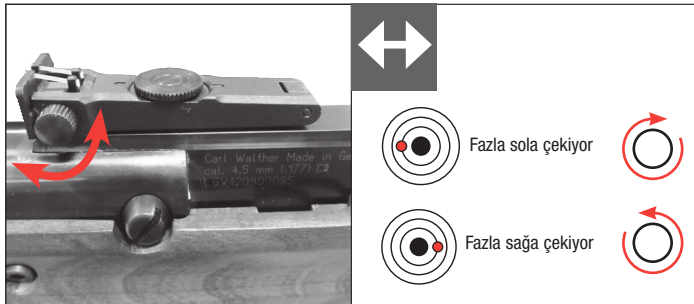

AŞAĞI-YUKARI AYARI

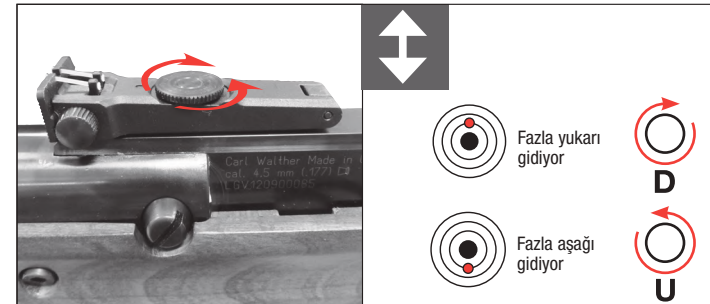



TR

⚠ DİKKAT

- Silahı sadece, emniyetli halde iken elinize alın.
- Namlunun her zaman güvenli bir yöne doğrultulmuş olduğuna dikkat edin.
- Silahın yüksek enerjisi nedeniyle, sadece mermilerin delip geçemeyeceği hedefler kullanın.

Dikkat! Dizginsiz geri tepme tüfeğin ve nişan dürbünün çok fazla zorlanmasına neden olacağından, tüfekte içinde mermi yokken ateş etmekten kaçınin.



Yatılı pistonlu tüfeklerle atış yaparken, tüfeğin dipçliğini çok fazla sıkı dayamamaya dikkat edilmelidir. Aksi halde atış hassasiyeti azalır. Farklı Diabolo çeşitleriyle alınan sonuçlar da farklıdır. Atıştan önce, hedefin ve çevresinin güvenli olduğundan emin olun. Sonra tetiği sakın bir şekilde sonuna kadar çekin. Tetiği çektikten sonra birkaç saniye daha hedef tahtasına nişan almaya devam edin. Dipçığı dayama şeklinizdeki bir değişikliğin isabet noktanızı da değiştireceğini dikkate alın.

Dikkat! Havalı tüfek mermi ve saçmalarını elinizle tuttuysanız elinizle yüz ve ağzınıza dokunmaktan kaçınin. Kurşun parçacıklarından kurtulmak için ellerinizi iyice yıkayın.

Boşa almak ve boşaltmak

Ateş etmemeye karar verdiyseniz, şu şekilde hareket edin:

Namluyu boşaltmak için önce tüfeği boşa alın. Bu amaçla namluyu en arkadaki trnak pozisyonuna kadar bükün ve namluyu bir elinizle sıkıca tutun, tüfeğinizin emniyetini açın ve tetiği çekin. **DİKKAT! Namluyu sıkıca tutun!**

Sonra namluyu yavaşça başlangıç pozisyonuna götürün.

Boşaltmak için namluyu, piston yayını germeden açın ve Diabolo'yu bir temizleme çubuğuyla namludan dışarı itin.

Tüfek kurulu ve namlu aşağı bükülmüş haldeyken kesinlikle tetiğe basmayın (istisna – boşa alma, bkz. yukarıda). Aksi halde namlu yukarı teper, eğrilir ve yaralanmalara neden olabilir! Piston germe çubuklarına vurur ve kırılabilir. Aynı şekilde kundak çatlayabilir ya da kırılabilir. **Böyle bir durumda her türlü garanti geçersiz hale gelir.**

Namlu bükülmüş haldeyken kesinlikle tetiği çekmeyin (istisna: boşa alma, bkz. yukarıda).

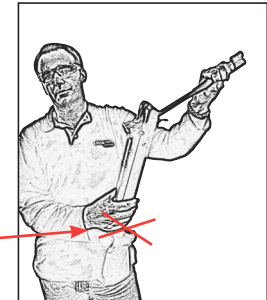

TR



NAMLUYU TEMİZLEMEK VE BAKIM

Tüfeğinizin kurulmamış ve boş olduğundan emin olun.

Namlu düzenli aralıklarla bu iş için öngörülmuş yardımcı araçlarla temizlenmelidir.

Namlu içi hasar görebileceğinden tel fırçalarla temizlik yapılması tavsiye edilmez. Dıştaki metal parçalar zaman zaman, daha önce silah yağıyla nemlendirilmiş yumuşak bir bezle temizlenmelidir ve namludaki menteşeler düzenli aralıklarla hafifçe yağlanmalıdır.

Dikkat! Havalı tüfeğinizi yaylı piston gergin durumda saklamayın. Yayda yorulma oluşabilir, bunun sonucunda da atış performansı düşebilir.

Temizleme pedi Ürün no. 3.2055

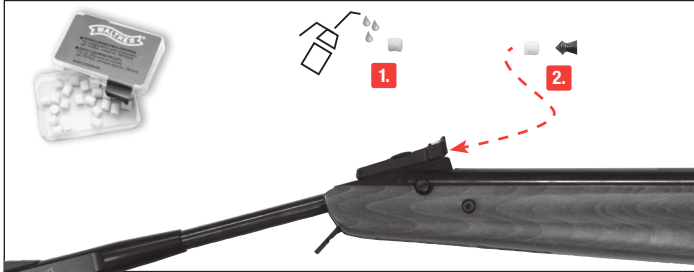

Temizleme çubuğu Ürün no. cal. 4,5 mm / cal. 5,5 mm 3.2054

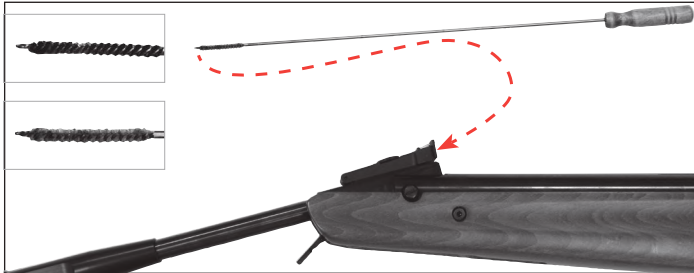

AKSESUARLAR VE PROBLEMLER

Metal tuning tetik
600.110



3 bölmeli susturucu
2.4849



Walther yay yağı, 10 ml
3.2061

Walther piston yağı, 30 ml
3.2060



PROBLEMLER

OLASI NEDENLER

PROBLEMLER	Silah emniyette	Namlu kirlî	Yanlış mühimmat	Mühimmat yanlış doldurulmuş	Piston ses çıkararak tımağa oturucaya kadar namluyu tekrar bükün	Emniyeti çözün ve tetiğe basın, arka vidada tetik sertlik ayarlarını kontrol edin
Kötü atış performansı		●	●	●		
Silah ateş almıyor	●		●	●	●	
Merminin hızı düşük		●	●	●		
Silah boşa alnamıyor. Tırnak oturmuyor.						●



KUNDAK YANAĞI

TR

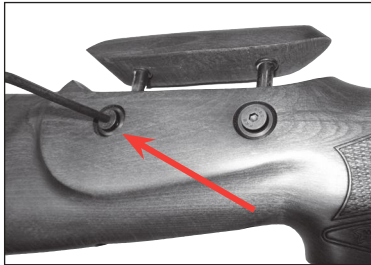

Sağ taraftaki iki vidayla, Competition Ultra modelindeki kundak yanağının yüksekliği ayarlanabilir.





TR



SUSTURUCU

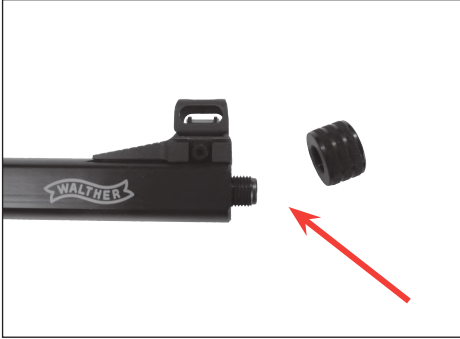

Susturucuyu monte etmek için önce namlu somunu çıkarılmak zorundadır. Ondan sonra susturucu namlunun ucuna vidalanarak takılabilir.





Distributed by

UMAREX

UMAREX GmbH & Co. KG

Donnerfeld 2

59757 Arnsberg | Germany

Phone: +49 29 32 / 638-01

Fax: +49 29 32 / 638-222

verkauf@umarex.de | sales@umarex.de

www.umarex.com

We reserve the right to make color and design changes and technical improvements. No responsibility is accepted for printing errors or incorrect information.

Änderungen in Farbe und Design, sowie technische Verbesserungen, Druckfehler und Irrtum vorbehalten. Alle Angaben ohne Gewähr.

Sous réserve de modifications de couleur et de conception, ainsi que d'améliorations techniques, de fautes d'impression et d'erreurs. Toutes les données sont fournies sans garantie.

Salvo modificaciones de color y de diseño así como mejoramientos técnicos, erratas y error. Todos los datos sin garantía.

Riserva di modifiche dei colori e del disegno, nonché di modifiche tecniche, errori di stampa e omissioni. Tutte le indicazioni sono fornite senza garanzia.

Изменения цвета и дизайна, а также технические улучшения, опечатки и ошибки не исключены. Мы не гарантируем точность сведений.

Zastrzegamy sobie prawo do pomyłek, błędów w druku, zmian koloru i designu, jak również do wprowadzania technicznych ulepszeń. Wszystkie informacje bez gwarancji.

Renk, tasarım ve teknik değişiklikler yapma hakkı saklıdır. Baskı hatalarından ya da hatalı bilgilerden dolayı yasal sorumluluk kabul edilmez. Bilgiler için garanti verilmez.

© UMAREX GmbH & Co. KG