

Wheeler[®]

Engineering
Fine Gunsmithing Supplies

Armorer's Handgun Sight Tool

Product #710905 Instructions #I054680 Rev. B

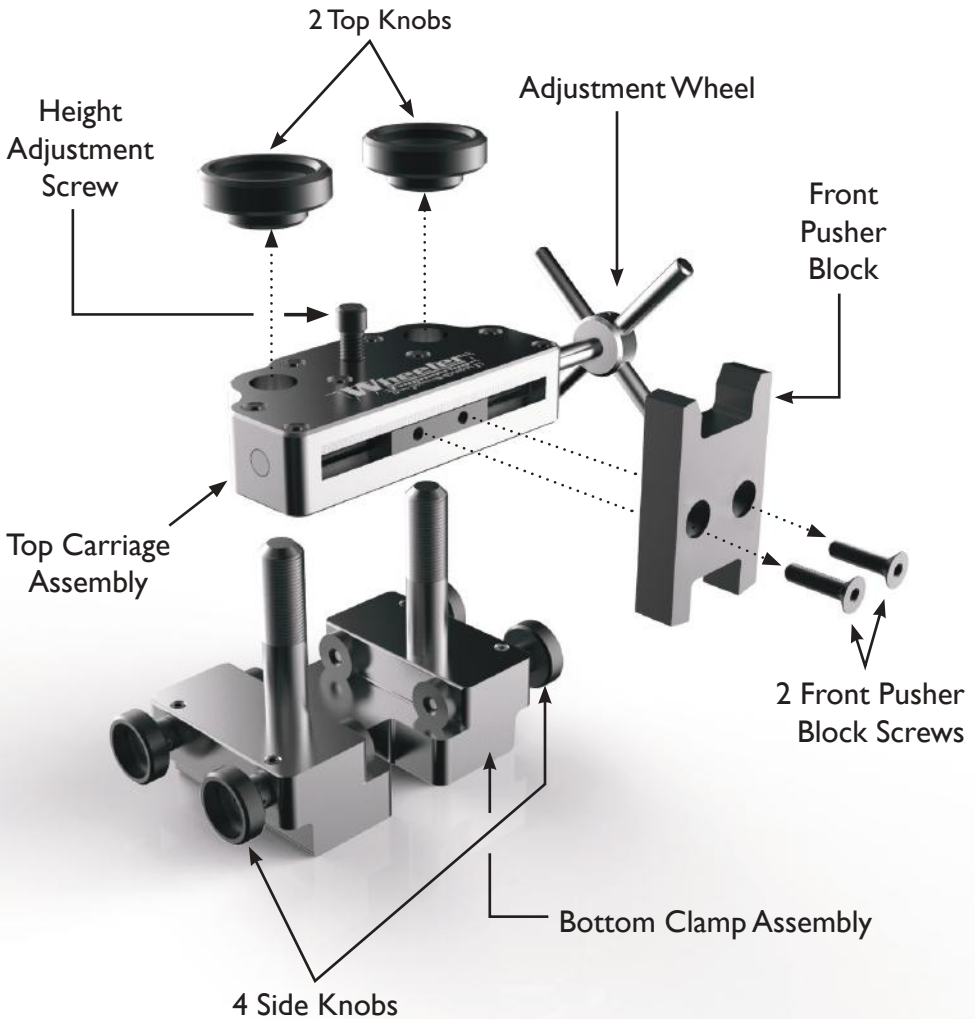

STOP!

If you have a problem with this product, **DON'T RETURN IT TO THE STORE WHERE YOU PURCHASED IT.** Contact customer service at...

Battenfeld[®]
Technologies, Inc.

2501 LeMone Industrial Blvd. / Columbia, MO 65201

573-445-9200 / Email: sales@btibrands.com

Or visit our website @ www.BTIbrands.com

NOT WARRANTED AGAINST MISUSE, ABUSE, OR COMMERCIAL USE.

Limited Warranty

Every Wheeler product is warranted to be free of defects in materials and workmanship for a period of one (1) year from the date of original purchase. Wheeler will, at its option, repair or replace without charge, except for transportation costs, parts that fail under normal use and service when operated and maintained in accordance with our Instructions. This warranty does not apply to normal wear or to items whose life is dependent upon their use and care. This warranty is in lieu of all other warranties, expressed or implied and releases Wheeler, its affiliates, and its vendors from all other obligations and liabilities.

IMPORTANT!

Adjusting or replacing sights can be difficult. These operations are best left to qualified gunsmiths. This tool has the ability to apply a significant amount of force to the components it contacts and can cause permanent damage or deformation if used incorrectly.

Battenfeld Technologies Inc. will not be held responsible for any damages resulting from unauthorized repairs and/or adjustments, or faulty installation.

Always wear safety glasses.

Battenfeld Technologies Inc. will not be held responsible for careless, unsafe firearm use, or personal injury or property damage of any kind resulting from such use.

Follow all safe firearm handling rules whenever attempting to make adjustments or modifications to firearms.

NOTE: Not all pistols, shooters or ammunition impacts in the same place. Pistols vary and may not shoot to the same point of impact, including identical models from the same manufacturer. Before making any adjustments, make sure your shooting form and ammunition are consistent enough to create easily identified groups.

SIGHT ADJUSTMENT

The following instructions are for both Front Sight adjustment or removal and Rear Sight adjustment or removal.

USAGE

- Adjust the height of the Top Carriage Assembly above the pistol slide by turning the Height Adjustment Screw in the Top Carriage Assembly. Make sure the height is adjusted so the Front Pusher Block will **NOT** drag across the top of the pistol slide when making the adjustment. **(Photo 4)**

(Photo 4)

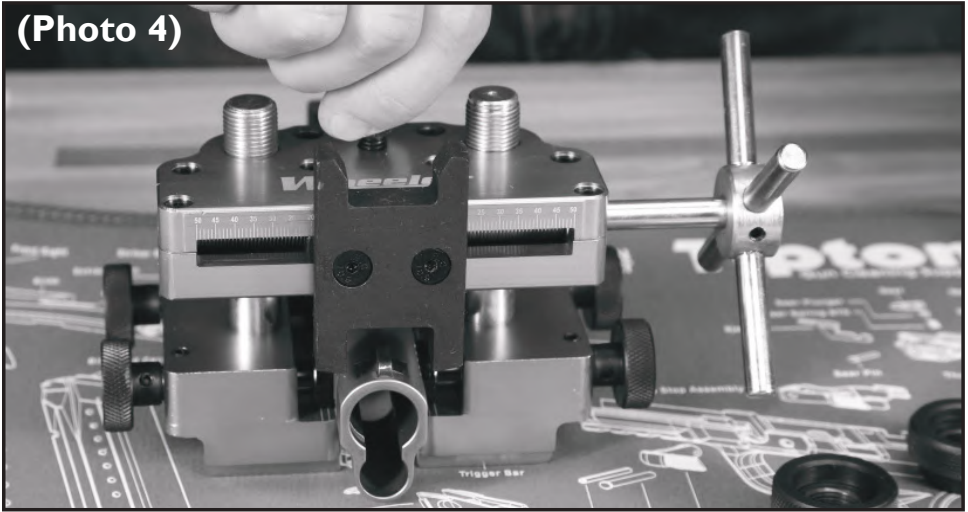

- Install the Knobs onto the Top Carriage Assembly. **(Photo 5)**

(Photo 5)

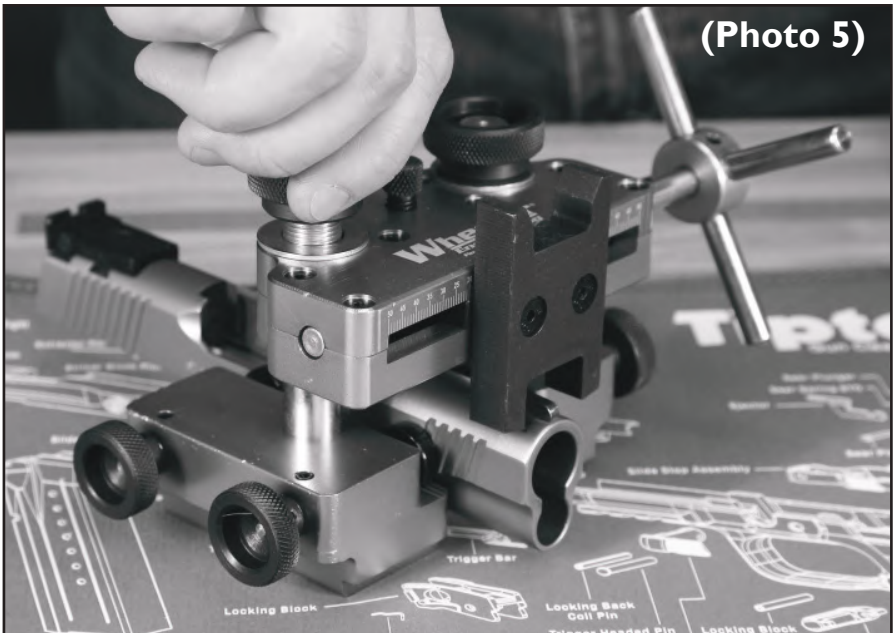

USAGE

7. Turn the Adjustment Wheel to position the Front Pusher Block near the sight. The Front Pusher Block must be positioned as close to the base of the sight as possible to prevent damage to the sight or dovetail. The sight must also be positioned so it is centered front to back with the Front Pusher Block. Tighten all 4 Side Knobs and the 2 Top Knobs to clamp the pistol slide securely in place (**Photo 6**)

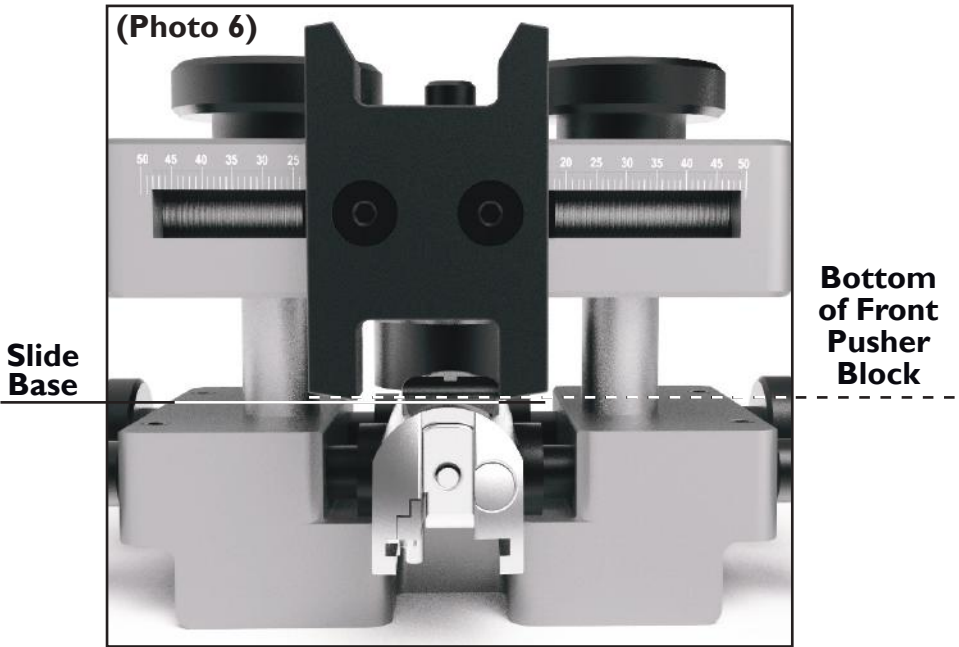

NOTE: Make adjustments to the position of the pistol slide and the height of the Top Carriage Assembly if needed to keep the Front Pusher Block centered and as low as possible without dragging across the top of the slide.

NOTE: There are alignment lines engraved into the base to help you keep the slide in alignment with the Front Pusher Block. This helps prevent miss-alignment and binding up the front sight during adjustment

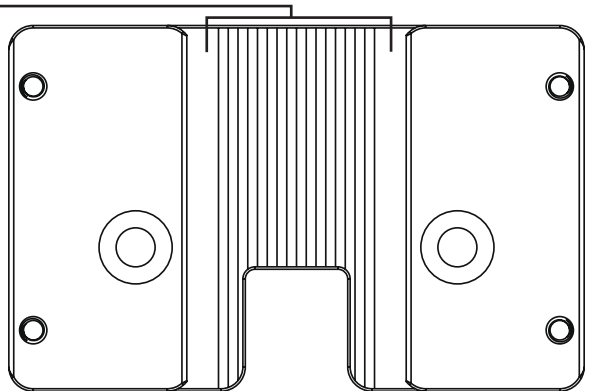

USAGE

- Turn the Adjustment Wheel to start pushing the sight. Apply force slowly and inspect the position of the Front Pusher Block often.



The Armorer's Handgun Sight Tool is a precision instrument. **DO NOT** apply force to the Adjustment Wheel during adjustment. This may cause damage to the Sight Adjustment Tool and to your sights.

During adjustment if the Front Pusher Block twists off vertical **STOP ANY FURTHER ADJUSTMENT.** (Photo 7)

(Photo 7)

Twisting of Front Pusher Block

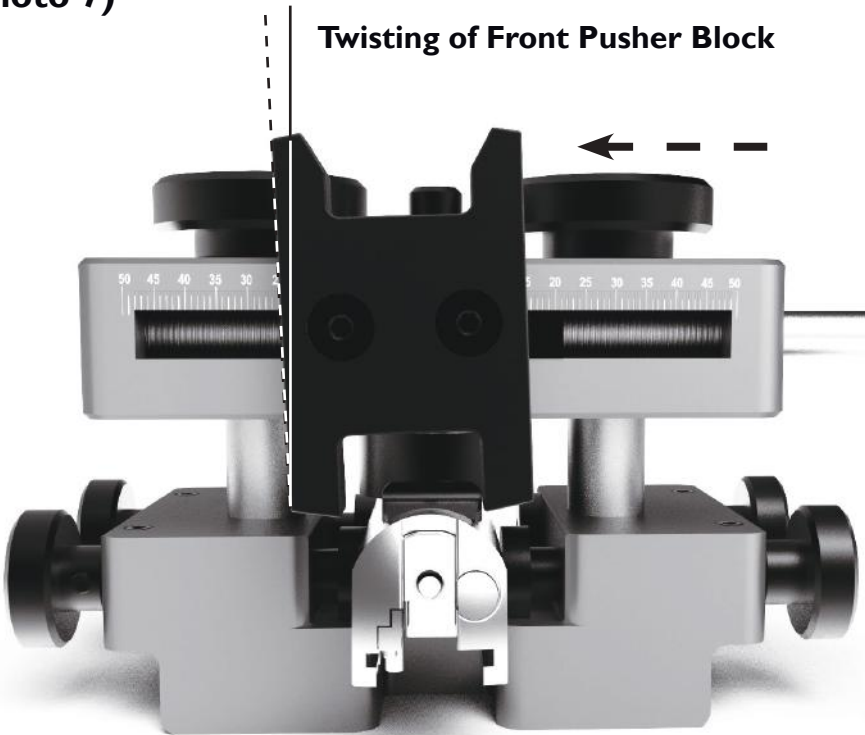

USAGE

If the sight is tight, tap on the bottom corner of the Front Pusher Block with a hammer and set punch in the direction the sight is being pushed. **(Photo 9)**

NOTE: Typically sights are installed from left to right. The left and right side are defined by the orientation the pistol is held when shooting. When looking down the slide as you would shoot the gun, the left side is the same as your left foot, right same as right foot.

Adjustments for correcting point of impact when shooting, can be made in either direction as needed.

NOTE: If removing the sights, contact the manufacturer to find out if there is a preferred direction. If this information cannot be obtained, push them from right to left. When reinstalling sights, push them from left to right.

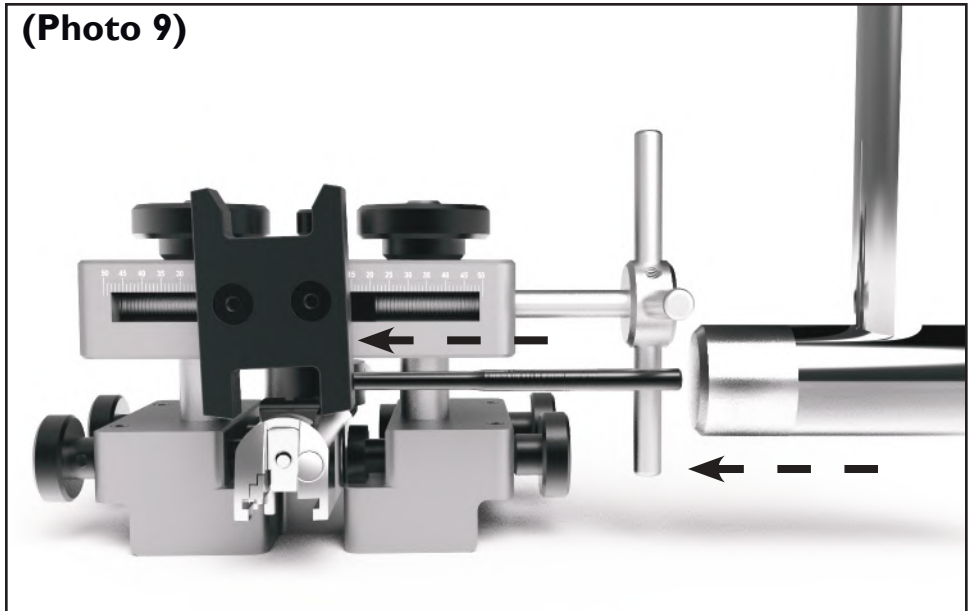

USAGE



IMPORTANT

DO NOT use any type of “cheater bar” or other device that increases the force pressure on the Adjustment Wheel or Front Pusher Block.

This may cause damage to the Armorer’s Sight Adjustment Tool, your slide, or your sight(s).



USAGE

9. When finished making the adjustment, or removing the sight:
 - A. Turn the Adjustment Wheel the opposite direction to remove pressure from the sight.
 - B. Loosen and remove the Knobs from the Top Carriage Assembly.
 - C. Remove the Top Carriage Assembly.
 - D. Loosen the Side Knobs and remove the pistol slide from the Bottom Clamp Assembly.

Reinstall or tighten set screws needed to hold sights in place.
Reassemble pistol slide to pistol frame and test for full function of all moving components before test firing.

SPECIAL CONSIDERATIONS (GLOCK®)

WARNING

Do not use the angled sides of the Front Pusher Block to adjust straight-sided sights. Doing so may result in damage to the sight or the pistol slide.

Some Rear Sights like those used on Glock® brand pistols are angled. To push these sights without damaging them, remove the 2 Front Pusher Block Screws and rotate the Front Pusher Block 180° to the angled orientation. Then re-seat the 2 Front Pusher Block Screws.
(Photos 8, 9, 10 and 11 on last page).

NOTE: DO NOT OVER TIGHTEN Front Pusher Block Screws.

The Correct Torque specs are:
50 lb-in or 6 N-m

SPECIAL CONSIDERATIONS (GLOCK®)

(Photo 8)



(Photo 9)

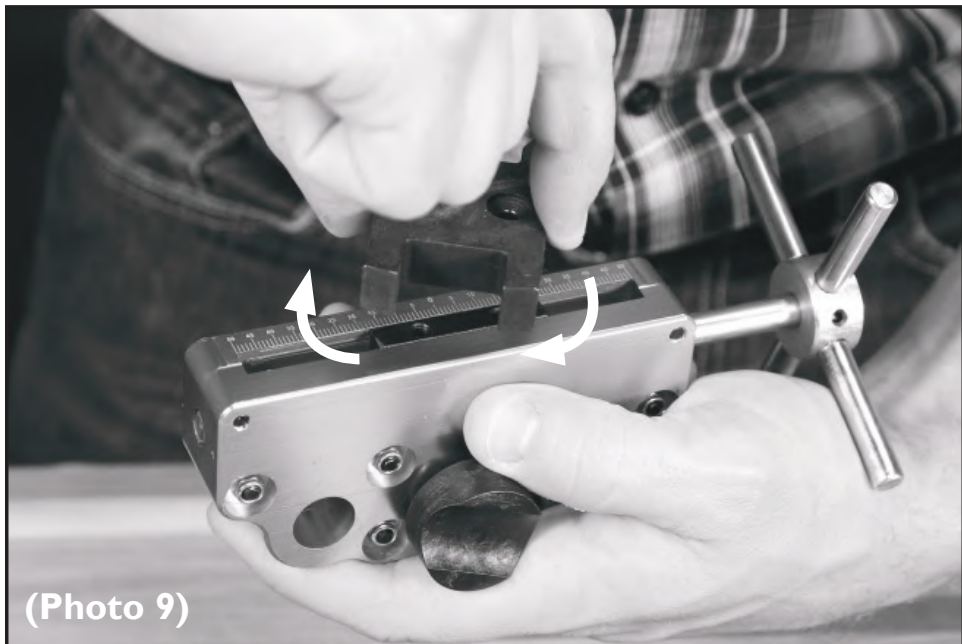

SPECIAL CONSIDERATIONS (GLOCK®)



(Photo 10)

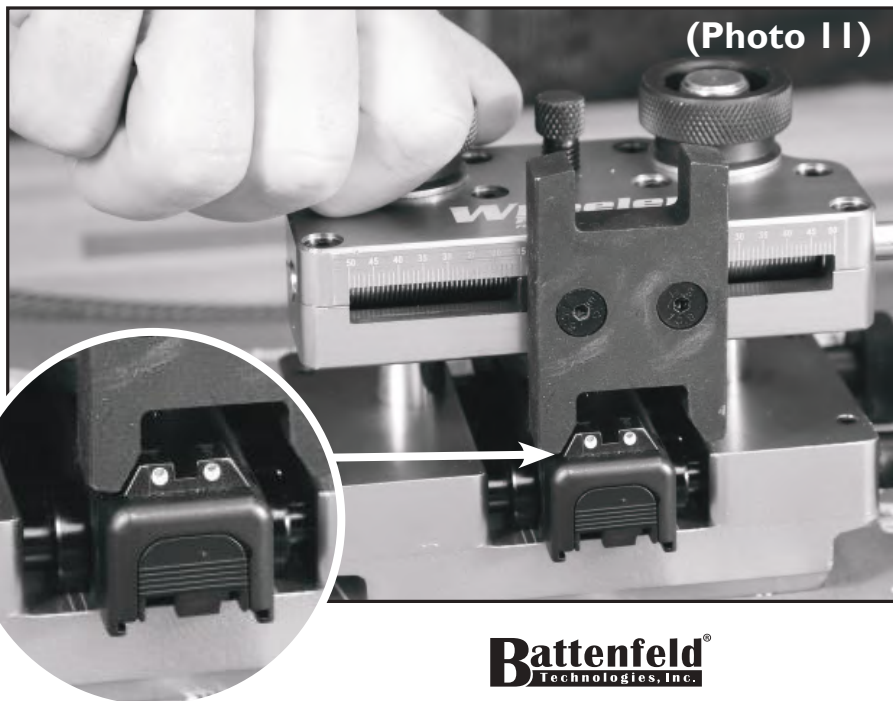

(Photo 11)

Battenfeld®
Technologies, Inc.

2501 LeMone Industrial Blvd. / Columbia, MO 65201
573-445-9200 / Email: sales@btibrands.com