

HYDRA



Day & Night Technologies

CONTENTS

HYDRA THERMAL SCOPE

General Information	01
Product Specifications	02
Features	03
HYDRA Main Parts and Controls	04
Power Supply	05
USB-C Data Transfer	06
On Screen Display	07
Quick Start Guide	08
Turning On/Off the device	08
Standby	08
Ocular Adjustments	08
Focus Adjustments	08
Zoom In/Out	09
Changing Thermal Color Palettes	09
Adjust Screen Brightness	09
Recording	09
Clip-On	10
Clip-On Zeroing	10
CONTROL DESCRIPTION	12

Menu List	13
Main Function	16
Zeroing Settings	16
Reticle Settings	17
Zeroing	18
Picture-in-Picture Function	19
Recoil Activated Recording	19
Hotspot Tracking	19
Auto Power Off	19
Loop Recording	20
Audio Recording	20
Thermal Imaging Modes	20
WIFI	21
APP User Menu	21
Installation DNT APP	21
Connecting App to Device	22
Access Recorded Videos Via the APP	24
FCC WARNING	25

HYDRA SERIES

HYDRA THERMAL SCOPE

SAFETY INSTRUCTIONS

- ⦿ Do not point the device at strong heat sources such as the sun, open flames, etc., as this may cause damage to the thermal sensor.
 - ⦿ Device operating temperature -4~122°F(-20~50°C).
 - ⦿ Please contact us if there are malfunctions, please do not attempt to disassemble the scope.
-

DESCRIPTION

HYDRA is a modular thermal scope that can be used 24/7, in all-weather conditions. It can be used as a standalone scope, handheld thermal scanner or a clip-on for LPVO and low magnification prism scopes.

PACKAGE CONTENT

- Hydra Thermal Scope
- Eye Cup
- Mount
- USB Cable
- User Manual

SPECIFICATIONS

Model	HS225	HS325	HS335	HS635	HS650	
Sensor Specifications	Resolution	256x192pixels	384X288pixels	384X288pixels	640x512pixels	640x512pixels
	Sensor	Uncooled Infrared Sensor				
	Frame Rate	50FPS				
	Pixel Size	12x12um				
	NETD	≤25mk (@25°C)		≤18mk (@25°C)		
	Focal Length of Objective Lens	25mm		35mm		50mm
	Base Magnification	3x	2x	3x	1.5x	2x
Digital Zoom	3x,4.5x,6x,9x,12x	2x,3x,4x,6x,8x	3x,4.5x,6x,9x,12x	1.5x,2.25x,3x,4.5x,6x	2x,3x,4x,6x,8x	
Display Specifications	Type	Micro - OLED				
	Display Resolution	1024x768pixels				
	Frame Rate	50FPS				
Power Specifications	Battery Type	18650 Battery (flat top type)				
	Operating Time	5.5h	4.5h	4.5h	4h	4h
	External Power Supply	5V - Type C USB				
Physical Specifications	Net Weight	372g / 13.1oz	380g / 13.4oz	389g / 13.7oz	389g / 13.7oz	416g / 14.7oz
	Dimensions	202x68x50mm 8.0x2.7x2.0inch	202x68x50mm 8.0x2.7x2.0inch	196x68x50mm 7.8x2.7x2.0inch	201x68x50mm 7.9x2.7x2.0inch	212x68x57mm 8.4x2.7x2.2inch
	Storage	Built-in Storage, 32GB				
	WIFI / APP	Yes (DNT)				
	Operating Temperature	-20-50°C / -4-122°F				
	Waterproof	IP67				
	Recoil Proof	800Gs				

■ FEATURES

- ≤18mk NETD Thermal Sensor
- 3 in 1 Thermal: Scope, Handheld & Clip-On
- Thermal Image Super Resolution
- Ultra Compact & Light Weight
- 18650 Li-Ion Rechargeable Battery
- Micro-OLED 1024x768px display at 50 fps
- One shot zeroing
- Picture-in-Picture



■ HYDRA MAIN PARTS AND CONTROLS

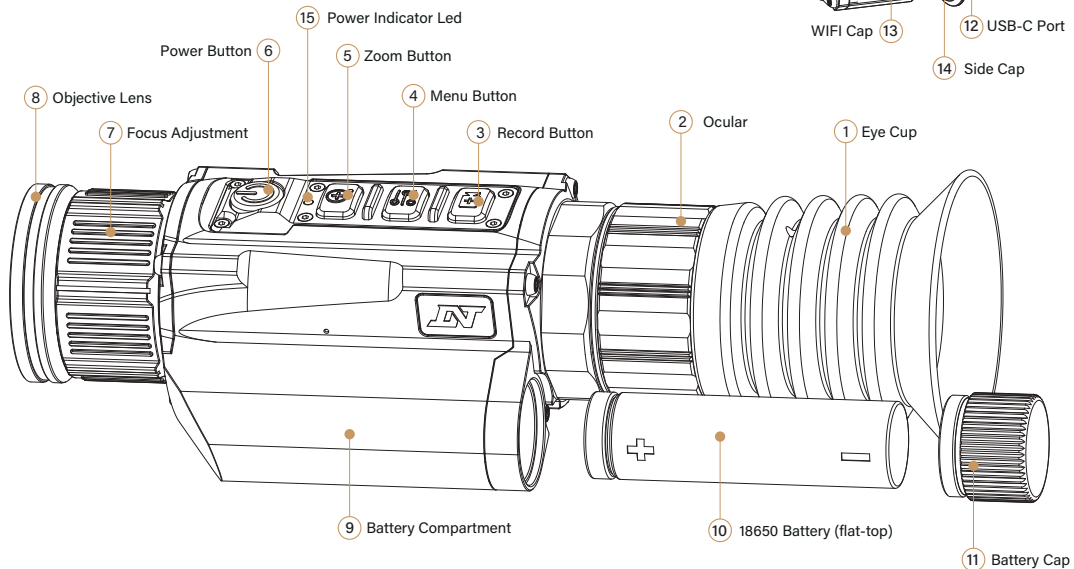

POWER SUPPLY

This device is powered by a rechargeable 18650 battery (flap-top). The HYDRA can also be powered using a USB power supply. The USB-C port does not charge the 18650 battery. Please remove the 18650 battery if using USB power and to recharge using external battery charger.

Installing the 18650 Battery

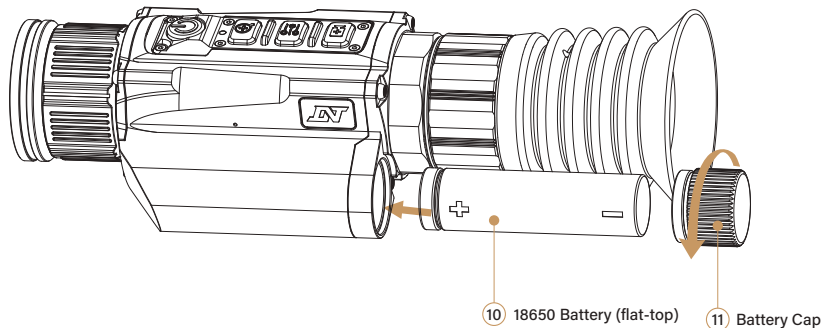

- Unscrew the Battery Cap **11**
- Insert 18650 battery **10** into battery compartment, positive end first
- Hand tightens the Battery Cap **11**

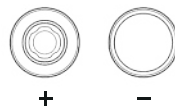

■ USB-C DATA TRANSFER

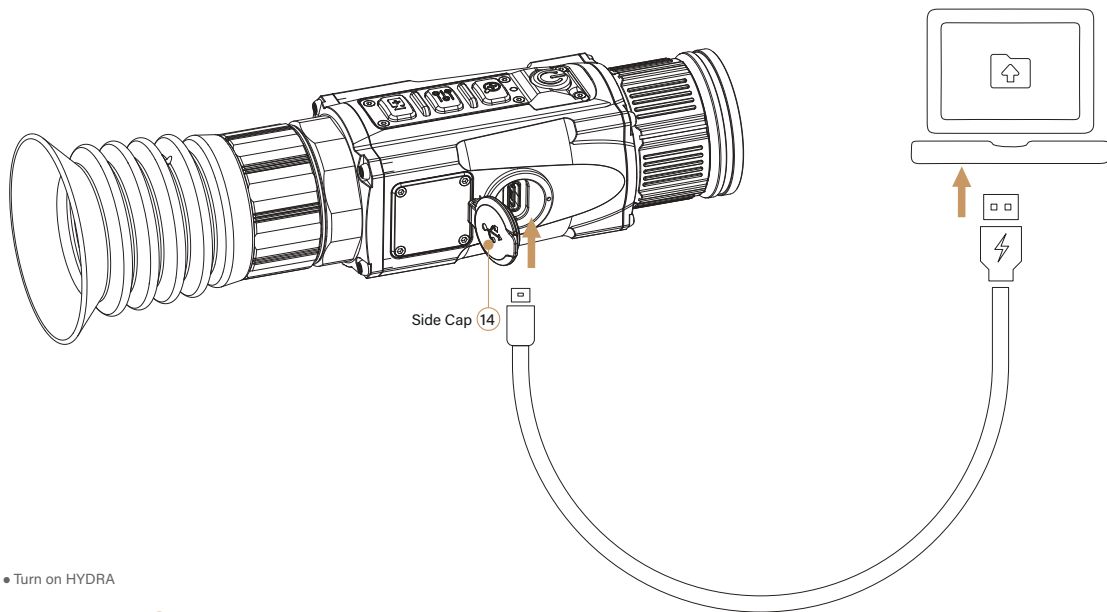

- Turn on HYDRA
 - Unplug the Side Cap 14 to reveal the USB-C port
 - Plug USB-C cable into HYDRA USB-C port. The HYDRA will connect to your computer like a USB drive*. You can browse and download video recordings to your computer as well as transfer files from HYDRA to your computer.
- * MacOS may require third party app to connect to HYDRA scope.

ON SCREEN DISPLAY

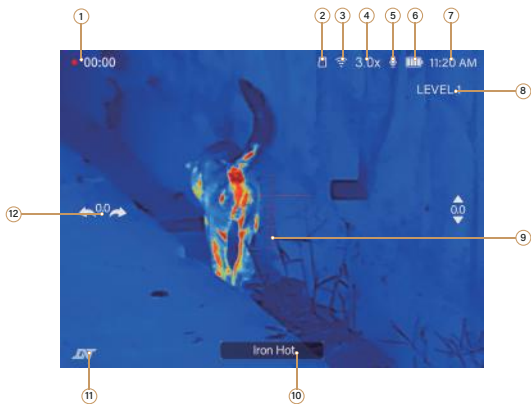

- ① Recording indicator: The recording timer indicates that the device is currently recording and duration.
- ② Storage warning status (when issues occur with storage)
- ③ WiFi (WiFi on, WiFi off don't display)
- ④ Current magnification (e.g. 3.0 x)
- ⑤ Microphone, indicates whether sounds to be included when recording
(microphone on, microphone off)

⑥ Battery Status

Icon	Status	Battery Status
	Low Battery	0% ~ 10%
	1 bar	10% ~ 20%
	2 bars	20% ~ 50%
	3 bars	50% ~ 80%
	4 bars	80% ~ 100%
	USB Powered	Connected to type C

⑦ Current Time

⑧ Current Screen Brightness Level

⑨ Reticle

⑩ Current Thermal Palette



⑪ DNT Logo

⑫ Gyroscope



■ QUICK START GUIDE

Turning On/Off the device

To turn on the device, press and hold the **Power Button** ⑥  for 2 seconds. The blue light indicator will turn on and the DNT logo will appear on the screen.

To turn it off, press and hold the **Power Button** ⑥ , a 2-second countdown timer will appear. Continue to hold the **Power Button** ⑥  to turn it off (the blue light indicator will also turn off)

Standby

Short press the **Power Button** ⑥  will place Hydra in standby mode. The screen will turn black, and the orange indicator light will appear. To exit standby mode, simply short the **Power Button** ⑥  again.

Ocular Adjustments

This is to achieve the best screen clarity for your eye, and it is independent of the target (therefore, you can set it with the objective lens cap closed). You can use the eye cup as a reference point for proper eye relief. Slowly spin the **Ocular** ② either left or right until you have achieved the best clarity of the screen. Once it is set, you don't need to adjust it anymore.

For Clip-On Mode, dial ocular adjustment to the mark.

Focus Adjustments

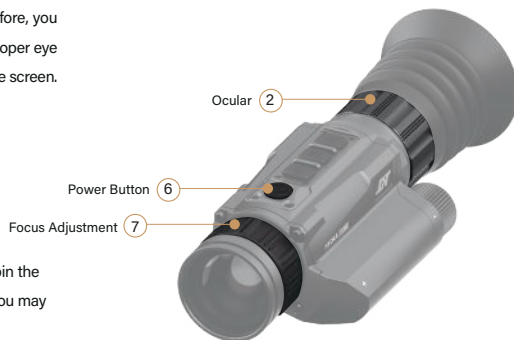

This is to adjust the focus of your image. Depending on how close or far you are to the target, spin the **Focus Adjustment** ⑦ either left or right to achieve maximum clarity. This is something that you may need to adjust frequently to ensure the target is in focus.



Zoom In/Out

Short press the **Zoom Button**  to cycle through different magnification levels.

Changing Thermal Color Palettes

Short Press the **Menu Button**  to change thermal color Palettes. There are currently four different thermal color palettes, press the **Menu Button**  to cycle through them.

Adjust Screen Brightness

Long press the **Zoom Button**  to cycle through different screen brightness levels.

Recording

Long press the **Record Button**  to manually record

Short press the **Record Button**  to turn on RAV (Recoil Activated Recording). This allows you to still capture 10 seconds of recording prior to pressing the button.



Clip-On

Thermal cannot see through glass, so please mount the Hydra in front of your LPVO, Prism or other low magnification optics.

Once mounted, activate Clip-On mode by either quickly double-pressing the **Record Button** (3) or long-pressing the **Menu Button** (4) to access the menu. To confirm your selection, short-press the **Menu Button** (4) . Dial your **Hydra Ocular** (2) to the zero mark (this mark is only used as a reference). Depending on the amount of space between the Hydra and your optics, slowly adjust the **Ocular** (2) for the best image.

Clip-On Zeroing

In summary, you need to move your Point of Impact (POI), thus the entire image, up/down/left/right to match with your Point of Aim (POA). To do so, short press **Record Button** (3) to move cursor down to zeroing mode.

- Aim at the target at preferred zeroing distance (we recommend 50 yards for Hydra). Adjust the **Objective lens** (8) so the target is now in focus. Fire one round at target, the bullet will impact on or near the target. For example, the impact point T as shown in Figure
- Step 2: Keep your HYDRA steady and reticle aimed at your original Point of Aim (POA), short press the **Power Button** (6) select from the menu to freeze the current image.
- Step 3: Adjust the X and Y values so the entire image (POI) will move towards the center of your cross hair/Point of Impact (POI) point T as shown in Figure (2). X & Y values can be adjusted by short press **Menu Button** (4) to make your selection and then move it Up/Down or Left/Right via **Zoom Button** (5) & **Record Button** (3)



Clip-On Zeroing

- Step 4: Move the cursor to "Save" and short press **Menu Button**  to save and exit.



Figure (1)

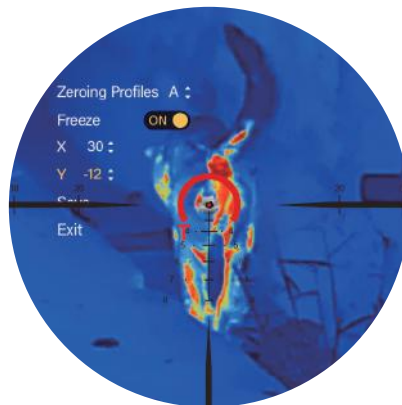
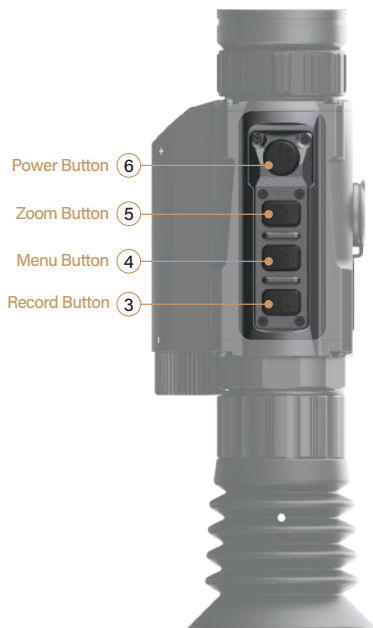

Figure (2)





Please see below for the master list of all the functions for each button.

CONTROL DESCRIPTION



Button	Status	Short Press	Long Press	Quick Double-Press
⑥	Off	--	On	--
	On	Standby	Off	--
	Standby	Wake-up	--	--
	Reticle Zeroing	Freeze/Continue	--	--
④	On	Thermal Palette	Open Settings Interface	Toggle Among :Natural / Enhanced / Highlight
	Time Setting/Date Setting	Move Cursor	--	--
	Menu	Confirm	Exit	--
	Reticle Zeroing	Select / Deselect	--	--
⑤	Defective Pixel Repair	Select / Deselect	--	--
	On	Increase Magnification	Screen Brightness Adjust	NUC
	Menu	Move cursor up	--	--
	Time Setting/Date Setting	Decrease Number/Value	--	--
	Reticle Zeroing	Move Cursor Up	--	--
③	Defective Pixel Repair	Move Cursor Up	--	--
	On	Start RAV Recording(manual mode)	Start/Stop Recording	Start/Stop Clip-On Mode
	Menu	Move Cursor Down	--	--
	Time Setting/Date Setting	Single increment adjustment	--	--
	Reticle Zeroing	Single increment adjustment	--	--
③	Defective Pixel Repair	Move Cursor Down	--	--

MENU LIST

Long press the **Menu Button** ④  to enter the settings menu. There are currently 10 different sections in total. Once you are in the settings menu, the three buttons work like your typical TV Remote, use **Zoom Button** ⑤  to move cursor up and **Record Button** ③  to move cursor down. Short press the **Menu Button** ④  to make the selection and long press the **Menu Button** ④  to go back.

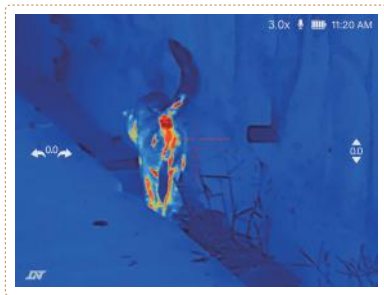

(main screen)





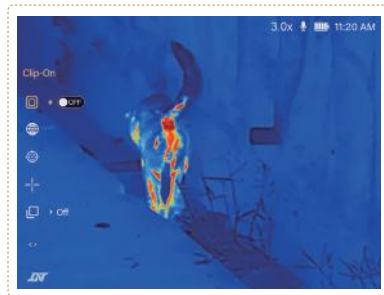



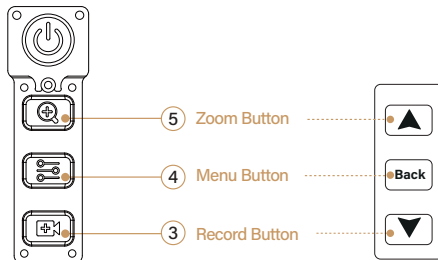

Long Press 2s



(menu)







Icon	Description
	【Clip-On】 ON / OFF
	【Connections】 Wi-Fi Setting
	【Reticle Zeroing】 Zeroing
	【Reticle Settings】 Reticles: 1-FFP / 2-FFP / 3-SFP / 4-SFP / 5-SFP / 6-SFP / 7-SFP / 8-SFP / Hide Reticle Colors: Red / Green / Yellow / Black / White
	【PIP Settings】 Off / Left / Center / Right
	【Recoil Activated Recording】 Auto Mode / Manual Mode / Off
	【Image Super Resolution】 ON / OFF

Icon	Description
	<p>【Thermal Image Settings】 Thermal Imaging Mode: Natural / Enhanced / Highlight NUC(Non-uniformity correction): Auto Mode / Manual Mode Palettes: White Hot / Black Hot / Red Hot / Iron Hot Image Contrast: 1-5 Image Brightness: 1-5 Image Sharpness: 1-5 Hotspot Tracking: ON / OFF</p>
	<p>【Function Settings】 Defective Pixel Repair: Move the cursor to the defective pixel for repair Auto Power Off: Auto Off shutdown time after sleep: Off / 10 / 20 /30minutes Loop Recording: Off / 1 / 3 / 5minutes Audio Recording: ON / OFF Gyroscope: ON / OFF / Calibration Screen Brightness: 1-5</p>
	<p>【System Settings】 Date / Time Language Setting: English / Français / Español / Deutsch / Italiano Format Restore Default Settings Available Storage Version</p>

MAIN FUNCTION

Zeroing Settings

Long press **Menu Button** ④  to enter the settings menu. Scroll down to Zeroing Menu and select your zeroing profile. To activate this setting, long press the **Menu Button** ④  for 2 seconds to enter the Settings Menu, short press the **Record Button** ③ , Short press the **Menu Button** ④  to enter the reticle zero interface.





Once you are in, first select your zeroing profile by short press **Menu Button** ④  to confirm your selection, there is a total of 26 (A-Z) profiles to choose from and each one of them can have its own reticle color, style and zeroing values.



- ① Zeroing Profiles A: Current zeroing Profile info. Total: 26 Profiles
- ② Freeze: Freeze / Unfreeze image
- ③ X=0: The horizontal position of the reticle (Left & Right)
- ④ Y=0: The vertical position of the reticle (Up & Down)
- ⑤ Save: Save & Exit
- ⑥ Exit: Exit without Saving
- ⑦ 3x: Magnification Setting

Reticle Settings

Reticle Colors

After making your reticle selections, short press the **Menu Button** (4)  to go back to the zeroing setting then move cursor down (**Record Button** (3) ) to short press **Menu Button** (4)  to select reticle colors (Red, Green, Yellow, Black and White). Short press **Menu Button** (4)  again to save your reticle color and go back to the zeroing setting.

Reticle Styles (add "Reticles" to the onboard menu)

Move cursor down (**Record Button** (3) ) and short press **Menu Button** (4)  to select reticle styles (1-8), reticle 1-2 is First Focal Plane (FFP) and reticles 3-8 are Second Focal Plane (SFP). Short press the **Menu Button** (4)  again to save your reticle color and go back to the zeroing setting.

Zeroing

- Step 1: Aim at the target at preferred zeroing distance (we recommend 50 yards for Hydra). Adjust the Objective lens **(8)** so the target is now in focus. Fire one round at target, the bullet will impact on or near the target. For example, the impact point **(T)** as shown in Figure (1).
- Step 2: Keep your HYDRA steady and reticle aimed at your original Point of Aim (POA), short press the **Power Button (6)** to freeze the current image.
- Step 3: Adjust the X and Y points of the reticle to move your Point of Aim (POA) to your Point of Impact (POI) point **T** as shown in Figure (2). X & Y values can be adjusted by short press **Menu Button (4)** to make your selection and then move it Up/Down or Left/Right via **Zoom Button (5)** & **Record Button (3)**
- Step 4: Move the cursor to "Save" and short press **Menu Button (4)** to save and exit.



Figure (1)



Figure (2)

Picture-in-Picture Function

In this mode, the small window magnification defaults to 10% of the large window. To turn ON or OFF the PIP position, enter the Menu: **PIP**  then select ON/OFF.

Recoil Activated Recording

Auto Mode

When the recoil force reaches 450Gs, it will automatically save a video with 10 seconds before and after the shot. For optimal performance, we suggest engage Auto Mode on firearms with recoil beyond .22LR.

Manual Mode

In this Mode, single press **Record Button**   to save a clip with 10 seconds before and after the shot, and long-press can also start/stop recording.

Off Mode

In this mode, long-press the **Record Button**   to activate/deactivate recording.

Hotspot Tracking

When activated, The screen will automatically display the highest heat source within the visible area.

Auto Power Off

Choose between 10, 20, or 30-minute auto power off intervals. The countdown initiates when the device switches to standby mode. We suggest enabling this function to prevent excessive battery consumption.



Loop Recording

The loop recording function offers 1, 3, or 5-minute video duration options. When enabled, recordings are restricted to the selected segment length, providing easy access to desired clips and preventing damage from sudden interruptions. Turning off this function allows for a seamless, long video recording.

Audio Recording

You can toggle this setting to decide whether to record audio with the video. It is enabled by default.

Thermal Imaging Modes

Natural

The thermal image appears to be most natural. This is the standard mode for all around purposes, where everything is most balanced.



Enhanced

The Thermal image is enhanced, but you will have more noise . This is where the thermal image is enhanced so you can see that fine detail but more pixelation will appear as well.

Highlight

Rapid target detection mode. The target heat source will pop and become more vivid, while surrounding environments will dim down to give you the highest contrast for heat source.

WiFi

WiFi is used to connect the Hydra scope to your cellphone/ tablet via the DNT OPTICS app. You DO NOT need an internet WiFi signal. To turn on WiFi, short press the **Menu Button**  to toggle between ON/OFF. Once it is set, long press the **Menu Button**  to go back.

■ APP USER MENU

Installation DNT APP

Download the DNT mobile app via the app store, or use the QR code below.



Android



iOS

Connecting App to Device

- Long press the **Menu Button**  for 2 seconds to open settings, select "Network Settings", and enable Wi-Fi. Please note, this is to connect your device to the APP; you don't need internet access to make it work.
- On your phone's Wi-Fi settings, select the device's Wi-Fi name, enter the password (12345678), and then click connect.

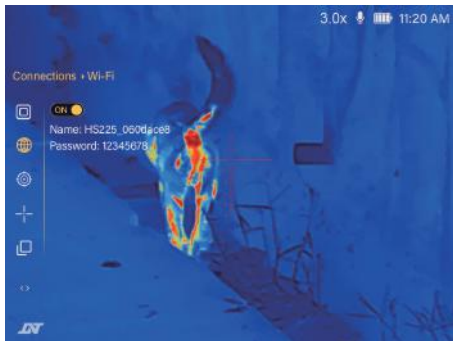
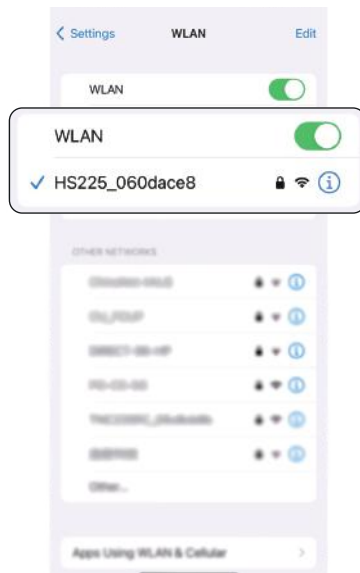
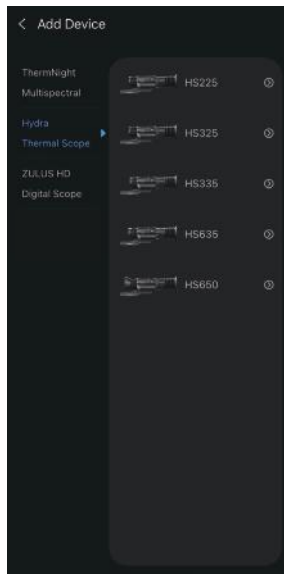

Figure (1)



- Start the "DNT" APP. Go to the Devices tab (at the bottom left of the screen). Click Add button on top right corner of the page. Select Hydra Series and select your specific model.



Access Recorded Videos Via the APP

Under the Album tab there are three options: **Device Files**, **Local Files** and **Edit Files**.



Device Files

This is where all the recorded videos are stored. You can only access them if the device is connected via Wi-Fi.

To save the videos to local files

Local Files: Videos stored in the APP. Select your videos under the Device Files tab and save them to Local Files. You can now access all of the saved videos via the APP even if the device is disconnected.

To save files to your phone/ tablet's album, select your videos and click the save icon.

Edit Files

Videos can be edited and shared on social media in this tab.

FCC WARNING

This device complies with part 15 of the FCC Rules. Operation is subject to the following two conditions: (1) this device may not cause harmful interference, and (2) this device must accept any interference received, including interference that may cause undesired operation.

Any changes or modifications not expressly approved by the party responsible for compliance could void the user's authority to operate the equipment.

NOTE: This equipment has been tested and found to comply with the limits for a Class B digital device, pursuant to Part 15 of the FCC Rules. These limits are designed to provide reasonable protection against harmful interference in a residential installation. This equipment generates, uses and can radiate radio frequency energy and, if not installed and used in accordance with the instructions, may cause harmful interference to radio communications. However, there is no guarantee that interference will not occur in a particular installation.

If this equipment does cause harmful interference to radio or television reception, which can be determined by turning the equipment off and on, the user is encouraged to try to correct the interference by one or more of the following measures:

- Reorient or relocate the receiving antenna.
- Increase the separation between the equipment and receiver.
- Connect the equipment into an outlet on a circuit different from that to which the receiver is connected.
- Consult the dealer or an experienced radio/TV technician for help. To maintain compliance with FCC's RF Exposure guidelines, This equipment should be installed and operated with minimum distance between 20cm the radiator your body: Use only the supplied antenna.



www.dntoptics.com