

KWA®

OPERATOR'S MANUAL

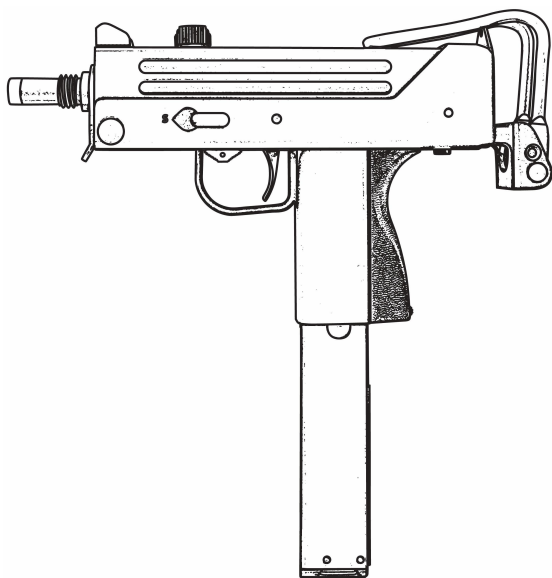

M11A1 NS2

TABLE OF CONTENTS

Use of this Manual	3
Safety Guidelines	3-4
Specifications	4
Package Contents	4
Charging Gas	5
Loading BBs	6
Locking Bolt	7
Loading Magazine	7
Selector	8
Safety	8
Retractable Stock	9
Shooting	9
Open Bolt	10
After Shooting.....	10
Hop-Up System	11
Adjustment Point	12
Disassembly	13-14
Assembly	15
Troubleshooting	16
General Maintenance	17
Operating Under Unusual Conditions.....	18
Diagrams and Parts Lists	19-22

USE OF THIS MANUAL

Before operating the Airsoft gun, read this manual in its entirety. Important safety topics and tips are discussed throughout all of the chapters. It's important that the operator know the principles of gun handling safety and operation prior to firing the Airsoft gun.

SAFETY GUIDELINES



WARNING! Failure to follow safety guidelines may result in serious injury.

Safety Distance

The effective shooting range is approximately 75 feet. BBs fired from this Airsoft gun may travel further than intended. Make certain that you have an adequate backstop.

Eye Protection

Eye protection should be worn at all times when both shooting and maintaining your Airsoft gun. Protect your eyes from BBs under pressure while performing maintenance on your Airsoft gun.

Assume Every Gun is Always Loaded

Until you are certain the chamber is empty, treat every gun as if it were loaded. Do not assume the chamber is empty based on your memory or someone else's words. Always remove the magazine and visually check to confirm the chamber is empty.

Beware of Barrel Obstructions

Ensure the Airsoft gun barrel is free of obstructions before you fire the gun. Even the smallest obstruction such as lubrication or a stuck cleaning patch can cause a misfire or malfunction.

Muzzle Control

Always keep the muzzle of the gun pointed in a safe direction. Never point the muzzle at a person or object that you do not intend to shoot.

Keep Your Safety On

Keep the gun's safety on until your sights are aligned on your target and you are ready to fire.

Keep Your Finger Off The Trigger

Keep your finger off the trigger and out of the trigger guard until your sights are aligned on your target and you are ready to fire.



WARNING! Airsoft BBs can be a choking hazard. Keep them away from children.

SAFETY GUIDELINES

Identify Your Target and Backstop

Before you pull the trigger, make certain of your target and what is beyond it. The Airsoft gun should never be fired at surfaces such as rocks, glass, water, or other hard surfaces where BBs are likely to ricochet in unpredictable directions.



WARNING! Adult supervision is required for any person under the age of 18.

Failure To Fire

If the Airsoft gun fails to fire, misfires, or malfunctions, do not look into the gun barrel. BBs can become lodged into the chamber, and serious eye injury may occur.

Maintain Your Gun Properly

Performing proper maintenance, as outlined in this manual, ensures that your Airsoft gun will be safe to shoot and will perform to its designed specifications for many years. Alterations, modifications or adjustments may damage your Airsoft gun, make it unsafe to shoot, and will void all warranty claims.

Store Your Gun Safely

Always store the Airsoft gun in a safe place, and out of the reach of children. Always transport the Airsoft gun in a carrying case. Never display the Airsoft gun in a public place. Keep the safety engaged, and remove the magazine before storing the Airsoft gun. Note: it is your responsibility to take every reasonable precaution to ensure the safe storage and transportation of your Airsoft gun.

Orange Tip

The orange tip on Airsoft guns helps Law Enforcement distinguish between the replica guns from their real firearm counterparts. Altering the coloration or markings required by state or Federal law so as to make the product look more like a firearm is dangerous and may be a crime. Operator assumes all risks and responsibility when doing so.

Hazards of Being Mistaken for a Real Firearm

Airsoft guns have been mistaken by Police and Law Enforcement as real firearms. A confrontation with law enforcement while carrying an Airsoft gun can result in serious injury or even death. It is strongly advised to operate the Airsoft gun at a safe and legal location. In the event that you are approached by Law Enforcement personnel, you must comply with their instructions immediately to avoid an incident.

Alcohol, Medications, and Drugs

Do not handle or operate your Airsoft gun while under the influence of alcohol, medication or drugs.

Your Responsibility

Your Airsoft gun is well-engineered and manufactured to the highest standards. It was carefully inspected before it was packaged and shipped from our factory. Its safe use depends on you alone. You are the ultimate safety device. Like many other devices, your Airsoft gun is safe unless handled in an irresponsible or uneducated manner.

SPECIFICATIONS

- Overall Length (Retracted) = 25.4 cm [10"]
- Overall Length (Extended) = 45.5 cm [17.92"]
- Overall Height = 25 cm [9.84"]
- Inner Barrel Length = 115 mm
- Inner Barrel Diameter = 6.05 mm
- Weight = 1.32 [2.91 lbs]
- Caliber = 6 mm
- Magazine Capacity = 48 rounds
- Rate of Fire = 20+ RPS
- Velocity = 103-110 MPS [340-360 FPS]
- Energy Output with 0.20g BB = 1.07 Joules
- Gas System = NS2
- Propellant = Green Gas

Special Features:

- Heavy duty construction with polymer casing
- Front sling loop
- Threaded barrel
- Functional cocking handle with realistic bolt movement
- Retractable shoulder stock
- Semi and full auto selective fire
- Adjustable hop-up

*Individual test results may vary depending on brand of BBs, ambient temperature, and chronograph used.

PACKAGE CONTENTS

- 1 M11A1 NS2 Airsoft gun
- 1 Bottle of Silicon Oil
- 1 Hi-Cap Magazine
- 1 Sample Bag of Airsoft BBs
- 1 Hop-Up Adjustment Tool
- 1 Operator's Manual

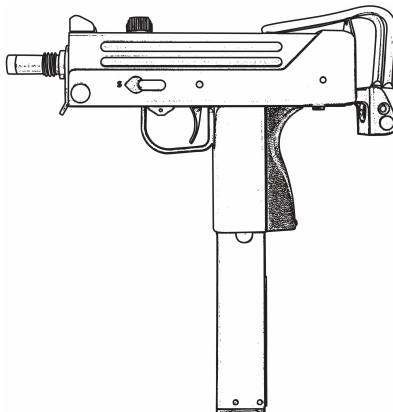

CHARGING GAS

1. Release the magazine by pressing the magazine catch.
2. Push the gas canister nozzle into the charging valve. (Make sure both the canister and magazine are inverted and in the vertical position when charging.)
3. Charge the magazine until gas overflows from the charging valve.



WARNING: Avoid dropping the magazine. Sudden impact with a hard surface may cause damage to the magazine.

Note: It is normal to have minor leaking from the charging valve during charging due to high pressure built up inside the magazine. It is recommended to keep the gas release valve slightly oiled. Room temperature is the ideal temperature for shooting. You may experience a delayed action if the surrounding temperature drops below 68° F.

Note: Do not expose the magazine to direct sunlight or incinerate the magazine, as this may cause the magazine to burst. It is strongly recommended to empty the gas from the magazine after shooting. Be certain that the gas does not make contact with eyes or skin while being released, as any contact will cause cold burns.

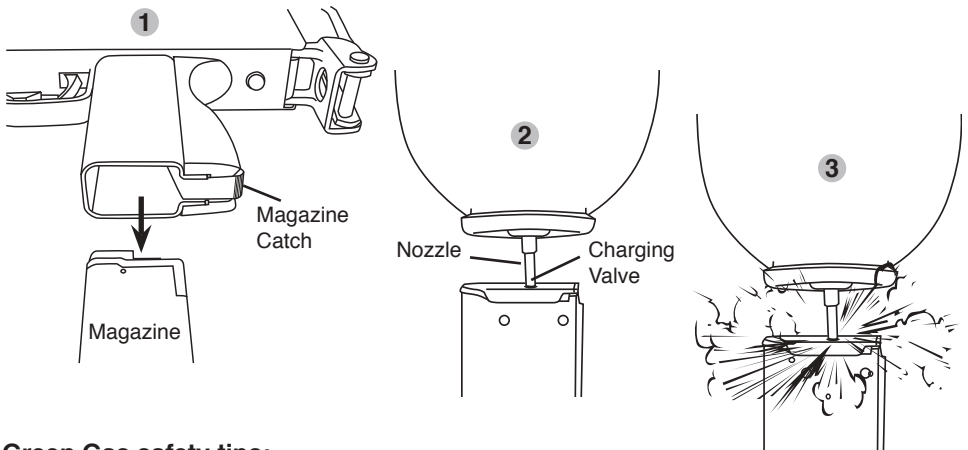

Green Gas safety tips:

- Check the canister for any cracks or leaks before using.
- Do not expose the canister to temperature over 104° F.
- Do not leave the canister directly over fire.
- Do not heat the canister.
- Keep the canister away from direct sunlight.
- Do not leave the canister in any type of vehicle.

LOADING BBs

1. Pull the magazine follower down until it locks.
2. Insert BBs into the magazine lip.
3. BBs should stack staggered for maximum round capacity.
4. Make sure to have a 3mm clearance between BBs and the top lip of the magazine.
5. Push the magazine follower lock to release.



WARNING: Always use high quality 6mm BBs, weighing 0.2g or heavier. For best result use 0.25g KWA Perfect BBs. Never use recycled or low grade BBs to prevent damage to your gun.



WARNING: Do not release the magazine follower when the magazine is empty. Doing so will damage the magazine and magazine follower.

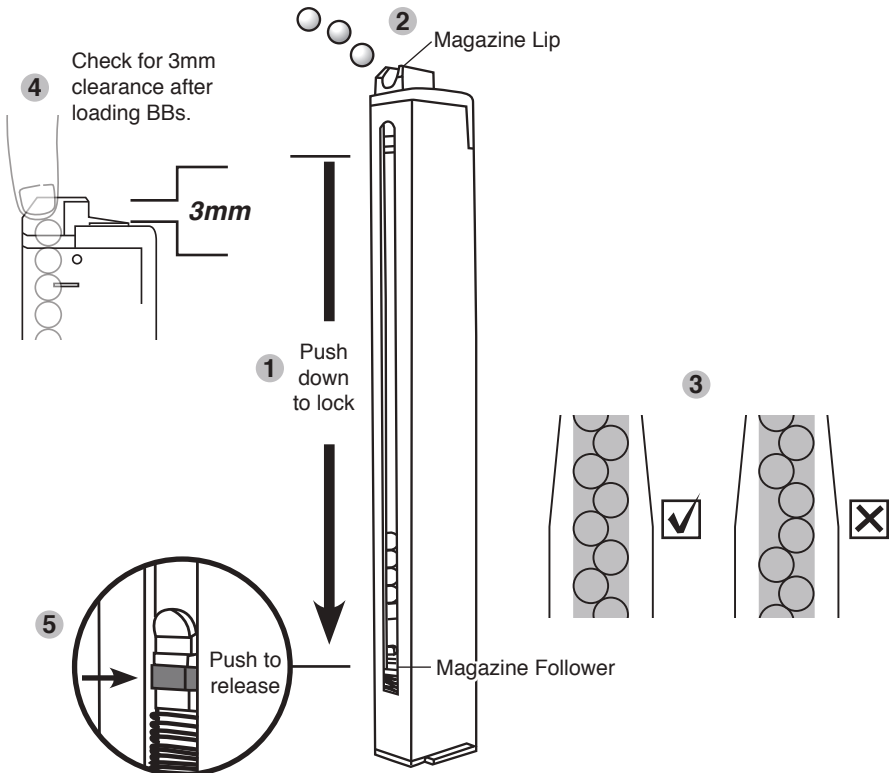

Locking Bolt

To lock the bolt, pull the bolt handle back to the rear of the gun.

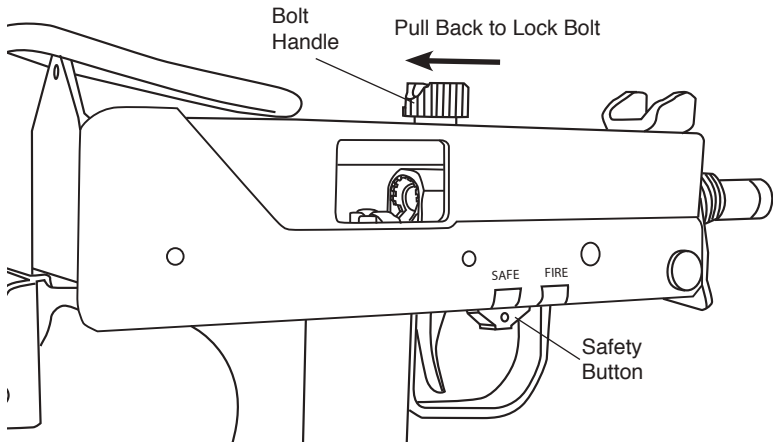

WARNING: To avoid accidental discharge due to inadvertent trigger pull, keep the manual safety engaged during loading or unloading.



WARNING: Always keep finger off the trigger until ready to fire. Make sure the muzzle is pointing in a safe direction.

LOADING MAGAZINE



WARNING: Before loading the magazine, the bolt must be in the locked position to avoid damaging the cylinder.

1. Pull the bolt handle back to lock the bolt.
2. Place the magazine into the magazine well.
3. Push the magazine up until it clicks into a locked position.
4. Pull the magazine down to assure that it has been locked in place.

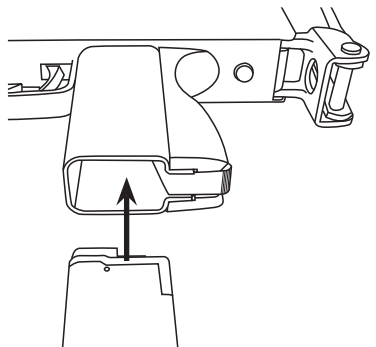

SELECTOR

The selector is located on the left side of the frame. Select (S) to fire semi-automatic (single shot) and select (F) to fire full automatic (continuous fire).

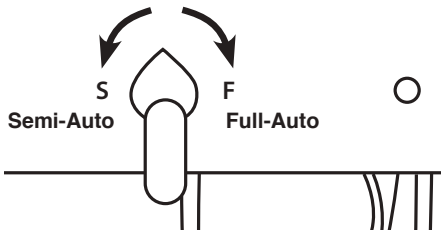

SAFETY

The safety button is located in front of the trigger. Safety is engaged when you push safety button to "SAFE". Safety is disengaged when you push safety button to "FIRE".

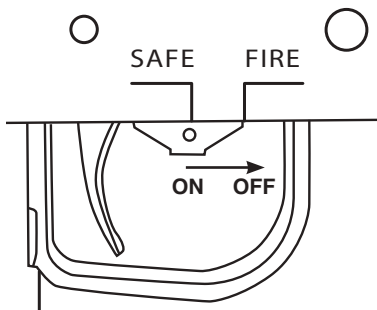

When the bolt is closed, bolt can be locked for storage by turning the bolt knob 90° counterclockwise.

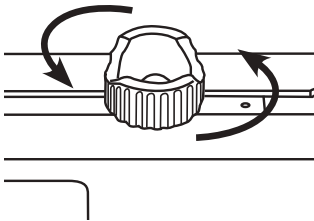

WARNING: Make sure safety is on at all times when not in a shooting position.

RETRACTABLE STOCK

1. Push the wire handles inward.
2. Swing the wire handles downwards until it locks.
3. Press and hold the stock button while pulling the stock slightly outward. Release the stock button.
4. Pull the retractable stock until the stock locks into position.

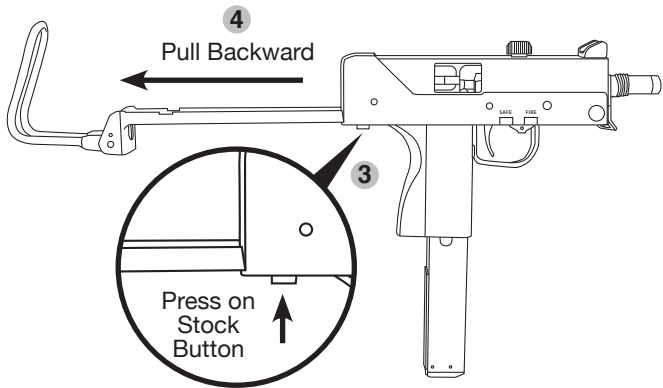
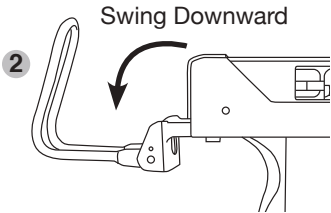
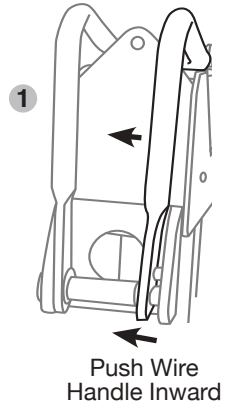

NOTE: To remove the retractable stock from the gun, press and hold the stock button and pull the stock out completely.

SHOOTING

1. Choose shooting mode. Select "S" for semi-auto or "F" for full-auto.
2. Disengage the safety.
3. Squeeze the trigger to fire.



WARNING: It is recommended eye protection be wore at all times. BBs may bounce off hard surfaces (ricochet). Always point gun in a safe direction.

OPEN BOLT

After the last shot has been fired and ejected. The bolt will lock halfway and the ejection port will remain opened.

NOTE: It is important to treat your gun as though it is loaded, even if the bolt remains open.

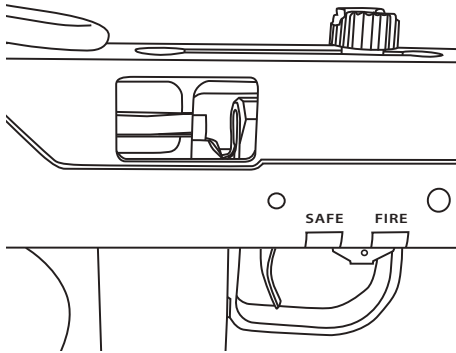

AFTER SHOOTING

Visually inspect the open bolt to check whether the magazine well and chamber are clear of BBs. When both the magazine well and chamber are clear, **ENGAGE SAFETY SWITCH**.

NOTE: Keep the chamber piston and seals oiled lightly with 100% silicone oil after shooting

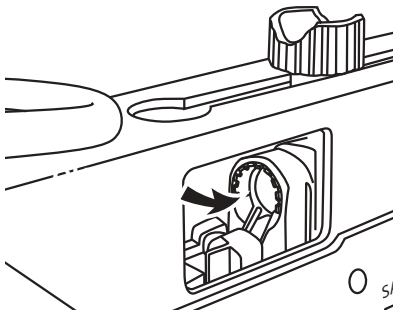

HOP-UP SYSTEM

The Hop-Up device is one of KWA's standard features, giving Airsoft BBs greater stability, further travel and increased accuracy. Airsoft BBs are light-weight and can be affected by wind when fired. With the Hop-Up system, the trajectory of the Airsoft BBs can be adjusted according to the shooting environment or surroundings.







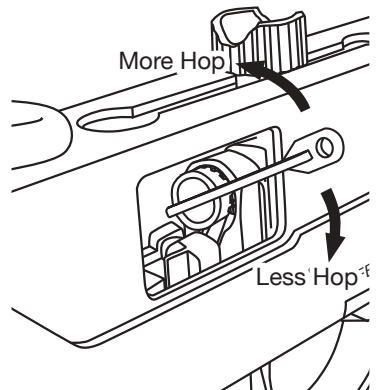
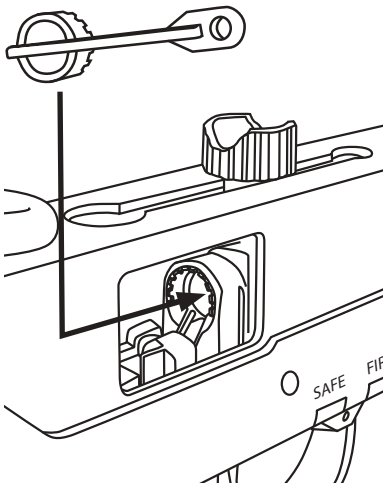







HOP-UP ADJUSTMENT

To adjust the Hop-Up, make sure the magazine is loaded and that you have at least 65 feet of clearance for a test fire before making any adjustments.

1. Test fire the gun for 10 to 20 rounds and observe the BB's traveling pattern.
2. Remove the magazine.
3. Open the slide and place adjusting tool into the slotted chamber ring. Turn the adjusting ring a 1/4-inch at a time.
4. If the BBs are dropping too quickly, move the adjusting ring to the left or counter-clockwise to give the BB more hop. If the BBs are dropping too slowly, move the adjusting ring to the right or clock-wise.
5. Test fire and adjust as needed.



ADJUSTMENT POINT

HOP UP EFFECTIVENESS	BB TRAJECTORY PATTERN		ADJUSTMENTS
<div style="border: 1px solid black; border-radius: 10px; padding: 5px; text-align: center;">NOT EFFECTIVE</div> 		BB DROPS FREELY	 TURN KNOB TO LEFT
<div style="border: 1px solid black; border-radius: 10px; padding: 5px; text-align: center;">SLIGHTLY</div> 		BB TRAVELS AT SHORT TRAJECTORY PATH	 TURN KNOB SLIGHTLY TO LEFT
<div style="border: 1px solid black; border-radius: 10px; padding: 5px; text-align: center;">PROPERLY</div> 		BB TRAVELS DISTANCE AT FLAT TRAJECTORY PATH	 NO ADJUSTMENT MADE
<div style="border: 1px solid black; border-radius: 10px; padding: 5px; text-align: center;">OVERLY</div> 		BB TRAVELS FLAT IN SHORT DISTANCE, THEN GOES UP IN CURVE AND DROPS FREELY	 TURN KNOB SLIGHTLY TO RIGHT
<div style="border: 1px solid black; border-radius: 10px; padding: 5px; text-align: center;">EXTREMELY EFFECTIVE</div> 		BB TRAVELS AT UNSTABLE SPEED AND IRREGULAR PATH	 TURN KNOB TO RIGHT

DISASSEMBLY

It is not recommended to disassemble the gun unless for general maintenance, or to clear BBs jammed inside the barrel.

1. Remove the magazine by depressing the magazine catch.
2. Remove the stock from the receiver (see pg13).
3. Pull the bolt handle to lock the bolt.
4. Check and clear the chamber from any BBs.
5. Using your finger tip, or small pen like tool, press down on the retaining pin 1, from within retaining pin 2, and pull it out from opposite end.
6. Pull retaining pin 2 out from the receiver. The pin is seated tightly in the receiver, considerable effort may be needed to pull it out.
7. Pull the upper frame upward and forward until it stops on bolt handle.

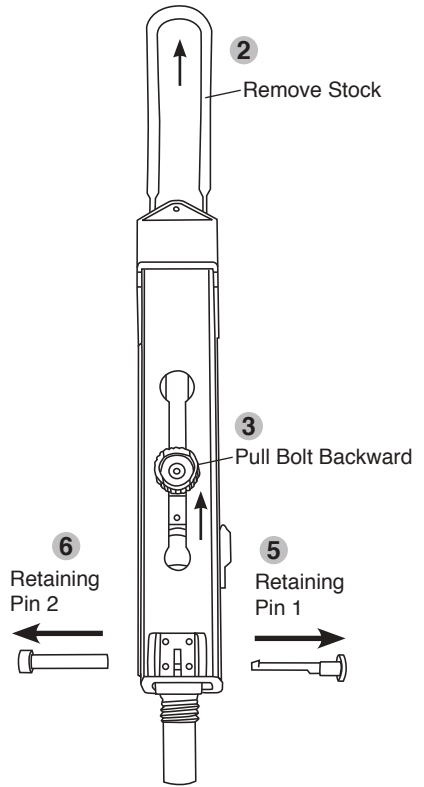

(continue on next page)

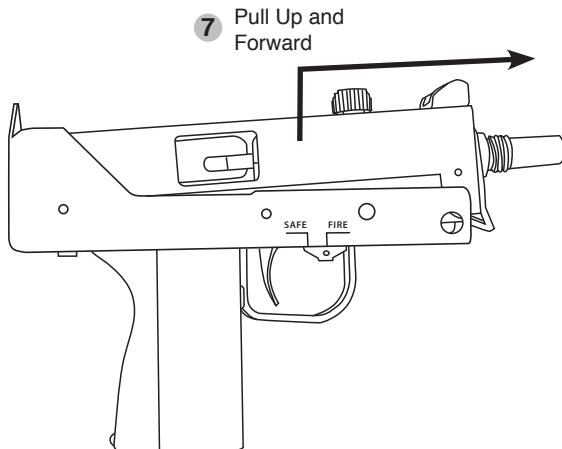

8. Turn the bolt knob 90° “clockwise” and pull the knob upward and out. The bolt handle “cut-out” should be aligned parallel to the slide in order to remove the bolt handle.
9. Remove the upper frame off of the lower frame.
10. After the upper frame is removed, push the bolt backward and then lift the bolt upward. Make sure the hook underneath the bolt clears the impact block.

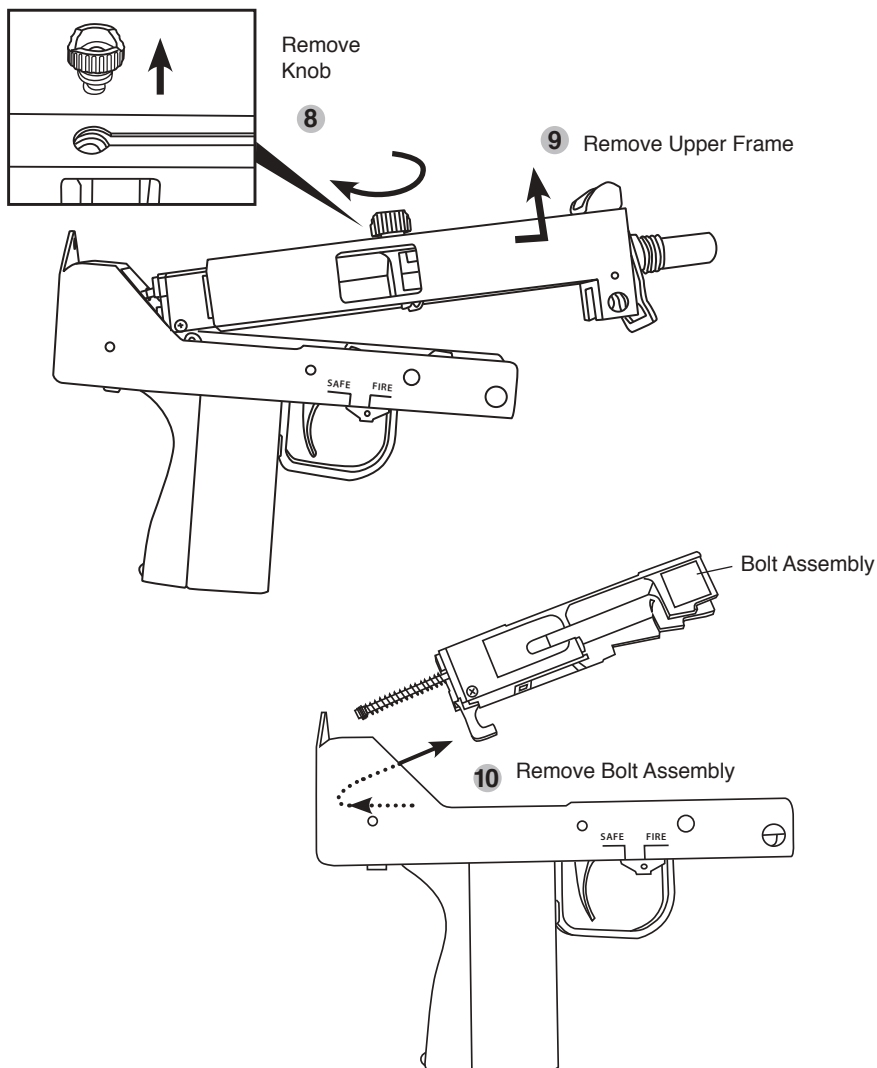

ASSEMBLY

1. Place the recoil spring onto the bolt assembly.
2. Lock the bolt assembly onto the upper frame.
3. Install the upper frame onto the lower frame and align the bolt knob hole. Make sure the hook underneath the bolt hooks onto the impact block
4. Push the bolt knob into the bolt assembly and push the slide assembly to the rear.
5. Align the retaining pin holes.
6. Insert the 2pc retaining pins.
7. Cycle the bolt to ensure proper assembly before shooting.

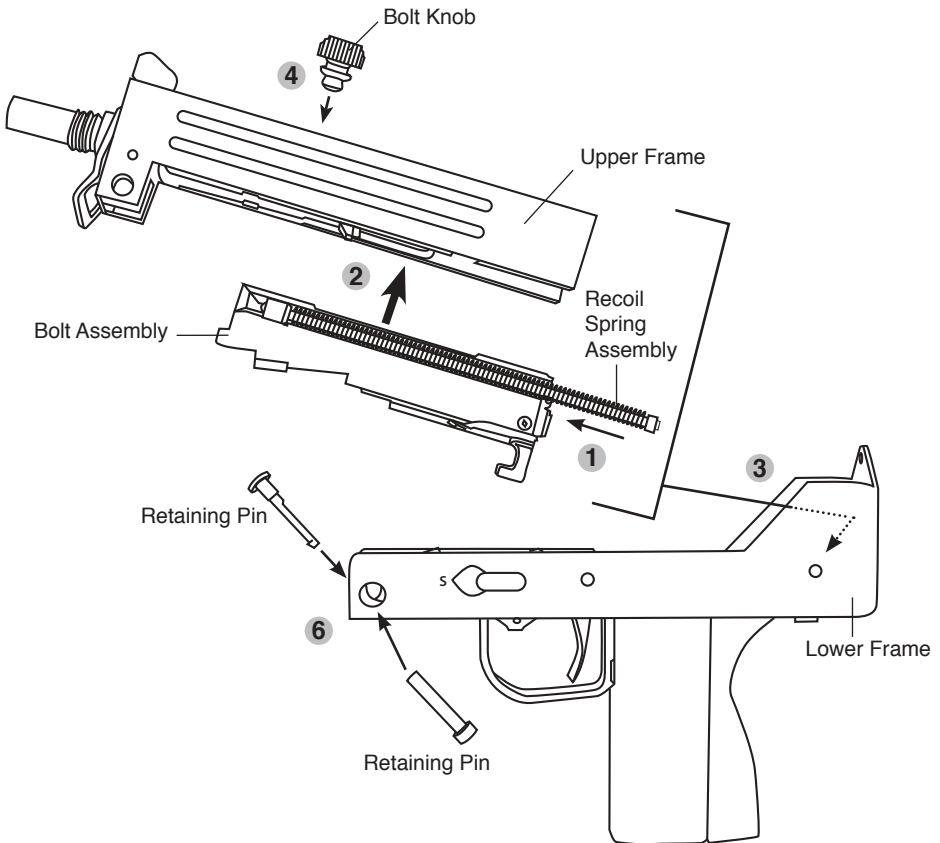

BASIC TROUBLESHOOTING GUIDE FOR SMG

SYMPTOMS	POSSIBLE CAUSE	SOLUTIONS
Bolt jams / Will not complete cycle	Dry internals	Add silicone to cylinder / main seal/ rails
Double feeds BBs into chamber / BBs roll out of barrel	Hop-up adjustment too tight	Release hop-up or replace bucking
BBs will not release from magazine / bent mag lip/ check BB condition	Bended magazine lip	Replace magazine lip
Leaking release valve & charging valve	Dry O-ring	Add silicone oil to valves / Replace valves
Magazine base plate will not lock	Broken base plate lock	Replace base plate lock
Magazine base leaking air	Worn out base seal	Replace magazine base seal
Cylinder will not load BBs into chamber	Broken Cylinder tap	Replace cylinder

GENERAL MAINTENANCE FOR KWA GAS BLOW BACK

Green gas is a liquid propellant which tends to dry out the seals and o-rings. With lubricating silicone oil, it will extend the life of the seals and o-rings and prevent gas leaks.

Use only the recommended 100% silicone oil, available for purchase at the Airsoft dealer where you purchased your KWA products. Any other type of lubricant may damage the products.

Lightly lubricate the recoil spring, cylinder and moving parts with a few drops of oil. Lubricating the seals and o-rings are essential. Unload BBs from the magazine. Make sure the magazine is free of gas before lubricating the magazine's charging valve and release valve.

OPERATING UNDER UNUSUAL CONDITIONS

Unusual conditions are defined as any condition requiring special maintenance. Perform maintenance outlined for the climate similar to your operational area

Extreme Cold:

Operating an Airsoft gas gun in extremely cold temperatures is not recommended. Cold temperatures will cause the Hop-up Bucking to harden, reducing its effectiveness. Gas will not expand properly in cold temperatures, so both the cycling rate and power will be dramatically reduced.

Extreme Heat:

Operating an Airsoft gas gun in extremely hot temperatures is also not recommended. Leaving the gun in direct sunlight for long periods of time, or operating in extremely hot areas will cause the gas to over-expand, damaging the internal workings of the gun. The increase in internal pressure from the expanding gas can also damage the seals and cause leaks in the magazine.

Dust or Sand:

Dust or sand can get into a gas gun and cause malfunctions and/or excessive wear. Keep the gun covered whenever possible. Use lubricant sparingly, as lube naturally attracts dirt and other particles. After use in a dusty area, always field strip the gun (refer to Disassembly Section) and clean any areas you can reach with a soft, lint-free cloth.

PARTS DIAGRAM

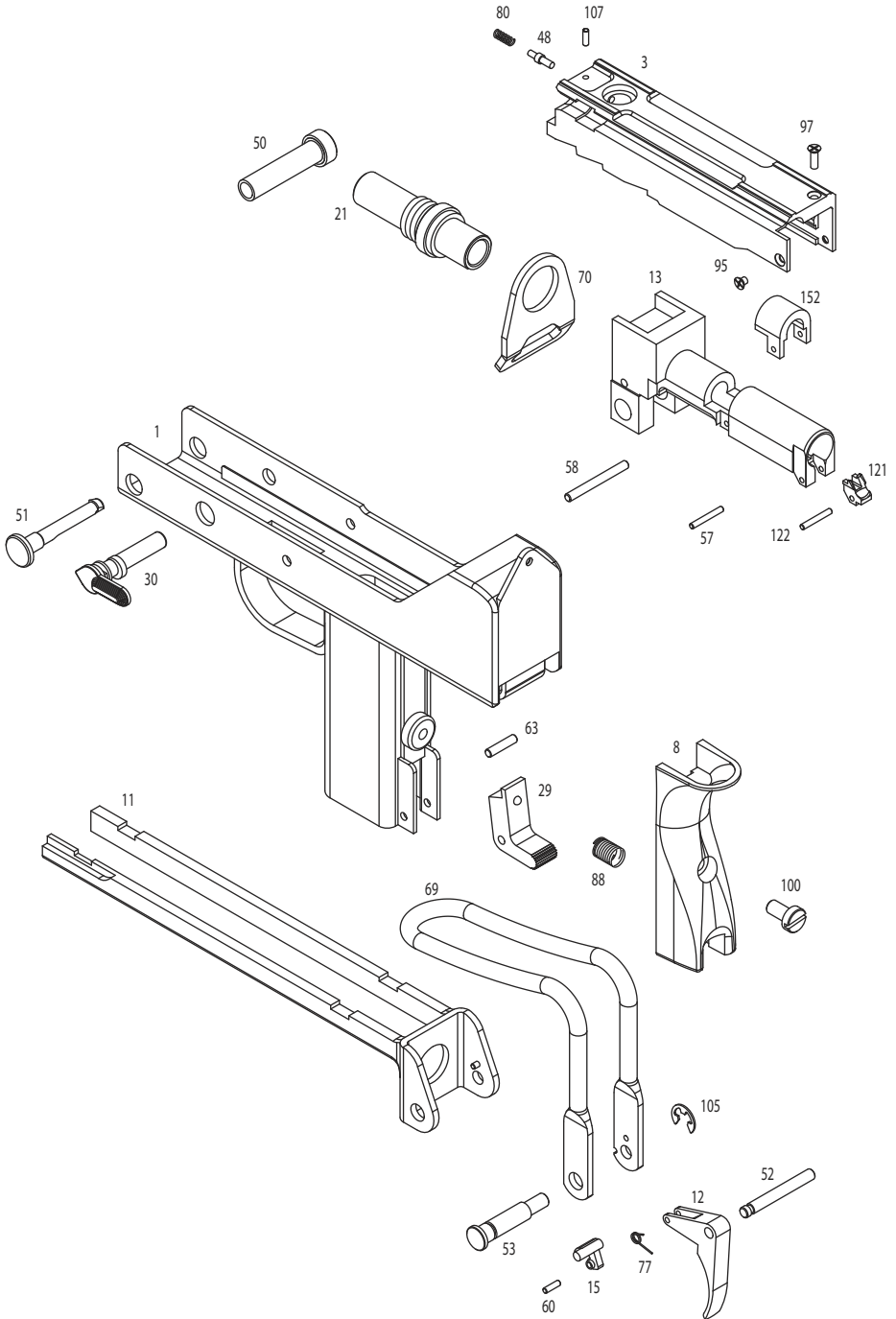

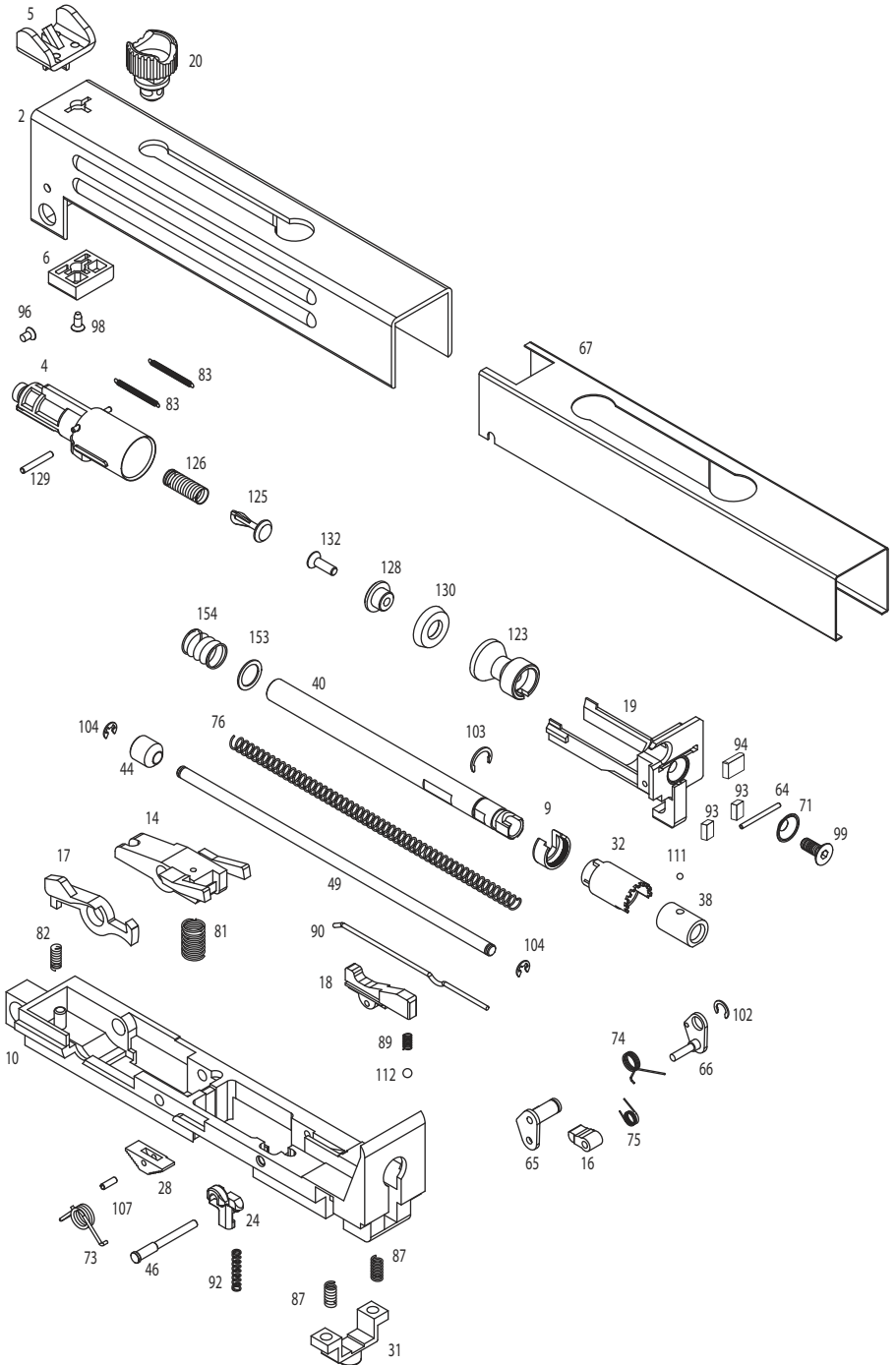

PARTS LIST

Parts #	Description	Parts #	Description	Parts #	Description
M11A1-1	Lower Frame	M11A1-51	Take Down Pin Lock	M11A1-93	Breech Buffer (Small)
M11A1-2	Upper Frame	M11A1-52	Trigger Pin	M11A1-94	Breech Buffer (Large)
M11A1-3	Bolt	M11A1-53	Stock Pin	M11A1-95	Breech Base Screw (Small)
M11A1-4	Cylinder	M11A1-57	Inner Barrel Clip Pin	M11A1-96	Breech Base Screw (Small)
M11A1-5	Front Sight	M11A1-58	Outer Barrel Retaining Pin	M11A1-97	Breech Base Screw (Large)
M11A1-6	Front Sight Base	M11A1-60	Sear Pin	M11A1-98	Front Sight Base Screw
M11A1-8	Grip	M11A1-63	Magazine Release Lever Pin	M11A1-99	Main Seal Base Screw
M11A1-9	Hop Up Cylinder Retaining Ring	M11A1-64	Cylinder Return Spring Retaining Pin	M11A1-100	Grip Screw
M11A1-10	Inner Frame Base	M11A1-65	Impact Block Housing (Left)	M11A1-102	Impact Block Housing Retainer
M11A1-11	Wire Stock	M11A1-66	Impact Block Housing (Right)	M11A1-103	Hop Up Cylinder Retaining Ring E-Clip
M11A1-12	Trigger	M11A1-67	Inner Slide Housing	M11A1-104	Recoil Spring Guide E-Clip
M11A1-13	Inner Barrel Base	M11A1-69	Folding Stock	M11A1-105	Folding Stock Pin E-Clip
M11A1-14	Bolt Stop	M11A1-70	Swivel	M11A1-107	Safety Pin
M11A1-15	Sear	M11A1-71	Main Seal Base Screw Washer	M11A1-111	Hop Up Ball Bearing
M11A1-16	Impact Block	M11A1-73	Trigger Spring	M11A1-112	Safety Switch Ball Bearing
M11A1-17	Sear Disconnecter	M11A1-74	Impact Block Housing Spring	M11A1-121	BB Feed Ramp
M11A1-18	Safety Base	M11A1-75	Impact Block Spring	M11A1-122	BB Feed Ramp Pin
M11A1-19	Breech Base	M11A1-76-1	Recoil Spring	M11A1-123	Main Seal Base
M11A1-20	Bolt Handle	M11A1-77	Sear Spring	M11A1-125	Alum Jet Nozzle
M11A1-21	Outer Barrel	M11A1-80	Bolt Handle Plunger Spring	M11A1-126	Jet Nozzle Spring
M11A1-22	Inner Barrel Clip	M11A1-81	Bolt Stop Spring	M11A1-128	Main Seal Cap
M11A1-24	Impact Block Reset Button	M11A1-82	Sear Disconnecter Spring	M11A1-129	Jet Nozzle Pin
M11A1-28	Safety	M11A1-83	Cylinder Return Springs	M11A1-130	Main Seal
M11A1-29	Magazine Release Lever	M11A1-87	Stock Release Button Springs	M11A1-132	Main Seal Cap Screw
M11A1-30	Selector Lever	M11A1-88	Magazine Release Lever Spring	M11A1-152	Inner Barrel Clip
M11A1-31	Stock Release Button	M11A1-89	Safety Spring	M11A1-153	Inner Barrel Spring Washer
M11A1-32	Hop Up Cylinder	M11A1-90	Trigger Pin Retaining Spring	M11A1-154	Inner Barrel Spring
M11A1-38	Hop Up Bucking	M11A1-92	Impact Block Reset Button Spring		
M11A1-40	Inner Barrel				
M11A1-44	Recoil Spring Guide Follower				
M11A1-46	Impact Block Pin				
M11A1-48	Bolt Handle Plunger				
M11A1-49	Recoil Spring Guide Rod				
M11A1-50	Take Down Pin				

MAGAZINE DIAGRAM AND PARTS LIST

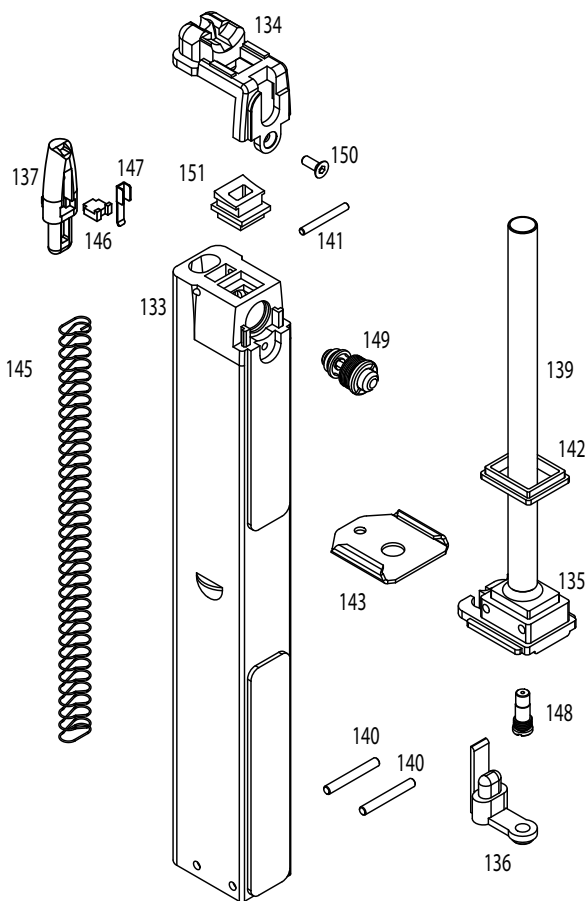

Parts #	Description
M11A1-MG133	Hi Cap Magazine Body
M11A1-MG134	Magazine Lip
M11A1-MG135	Magazine Base
M11A1-MG136	Magazine Base Plate Lock
M11A1-MG137	Magazine Follower
M11A1-MG139	Hi Cap Magazine Gas Expansion Tube
M11A1-MG140	Magazine Base Pins
M11A1-MG141	Magazine Lip Pin
M11A1-MG142	Magazine Base Seal

Parts #	Description
M11A1-MG143	Magazine Base Plate
M11A1-MG145	Hi Cap Magazine Follower Spring
M11A1-MG146	Magazine Follower Lock
M11A1-MG147	Magazine Follower Lock Leaf Spring
M11A1-MG148	Magazine Charging Valve
M11A1-MG149	Magazine Release Valve
M11A1-MG150	Magazine Lip Screw
M11A1-MG151	Magazine Nozzle Seal

KWA Performance Industries, Inc.

Copyright © July, 2009 KWA Performance Industries, Inc. All Rights Reserved.