

AEA

PRECISION AIRGUNS



AEA SONIC AIR RIFLE USER'S MANUAL

WWW.AEAIRGUN.COM

CONTENTS

SAFETY WARNINGS & IMPORTANT NOTICES	2
Exploded Diagram	7
Air Filling Procedure	13
LOADING, COCKING & FIRING	16
CLEANING & MAINTENANCE	20
Exterior Cleaning	
STORAGE	22
WARRANTY — ONE-YEAR LIMITED WARRANTY	24
Manufacturer's Rights	26

SAFETY WARNINGS & IMPORTANT NOTICES



Read this manual completely before operating your air rifle.

Failure to follow these instructions may cause damage, serious injury, or death.

General Safety Rules

Always treat the rifle as if it is loaded.

Never point the muzzle at anything you do not intend to shoot.

Keep your finger off the trigger until ready to fire.

Always maintain muzzle control, even if you slip or fall.

Use only in a safe, controlled environment with a confirmed backstop.

Wear ANSI-rated eye protection at all times.

Authorized Users

This PCP rifle is intended for adults only or for use under strict adult supervision.
This is not a toy.

Correct Ammunition

- Pellets and slugs only of the correct caliber.
- Do not use steel, alloy, or homemade projectiles.
- Do not reuse slugs.

Using unauthorized projectiles may damage the rifle and void the warranty.

Never Fire Without Air

Do NOT fire the rifle when:

- The air cylinder is empty
- The air cylinder is removed

Dry-firing without air may cause internal damage.

No Modification

Do not modify, disassemble, tune, polish, drill, or alter any internal component.

This includes the trigger, valve, hammer, regulator, and safety system.

Unauthorized modification voids the manufacturer's warranty.

AIR FILLING & PRESSURE GUIDELINES

Approved Air Only

Fill the rifle with dry, filtered compressed air only.

Never use

Oxygen, Hydrogen, Acetylene, CO₂, Nitrogen, or any other gas.

Using improper gases may cause explosion, severe injury, or death.

Filling Pressure

Maximum fill pressure: **480 BAR / 7000 PSI**

Overfilling is not covered under warranty.

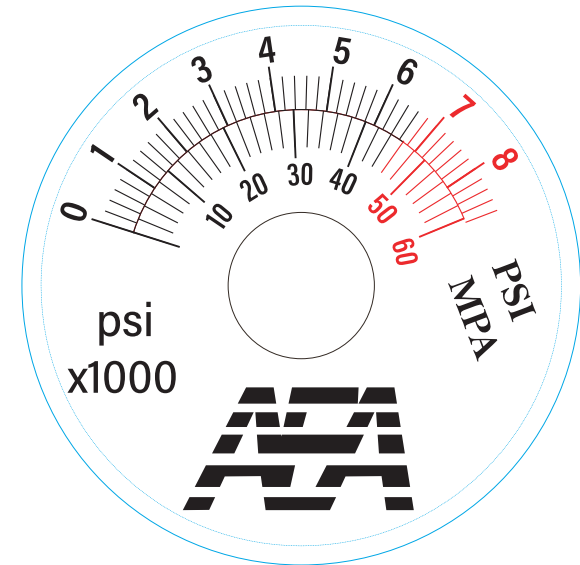

Air Tank Inspection

Inspect and recertify air tanks according to the dates and intervals printed on the tank label.

Exploded Diagram

AEA Sonic Compact DIAGRAM

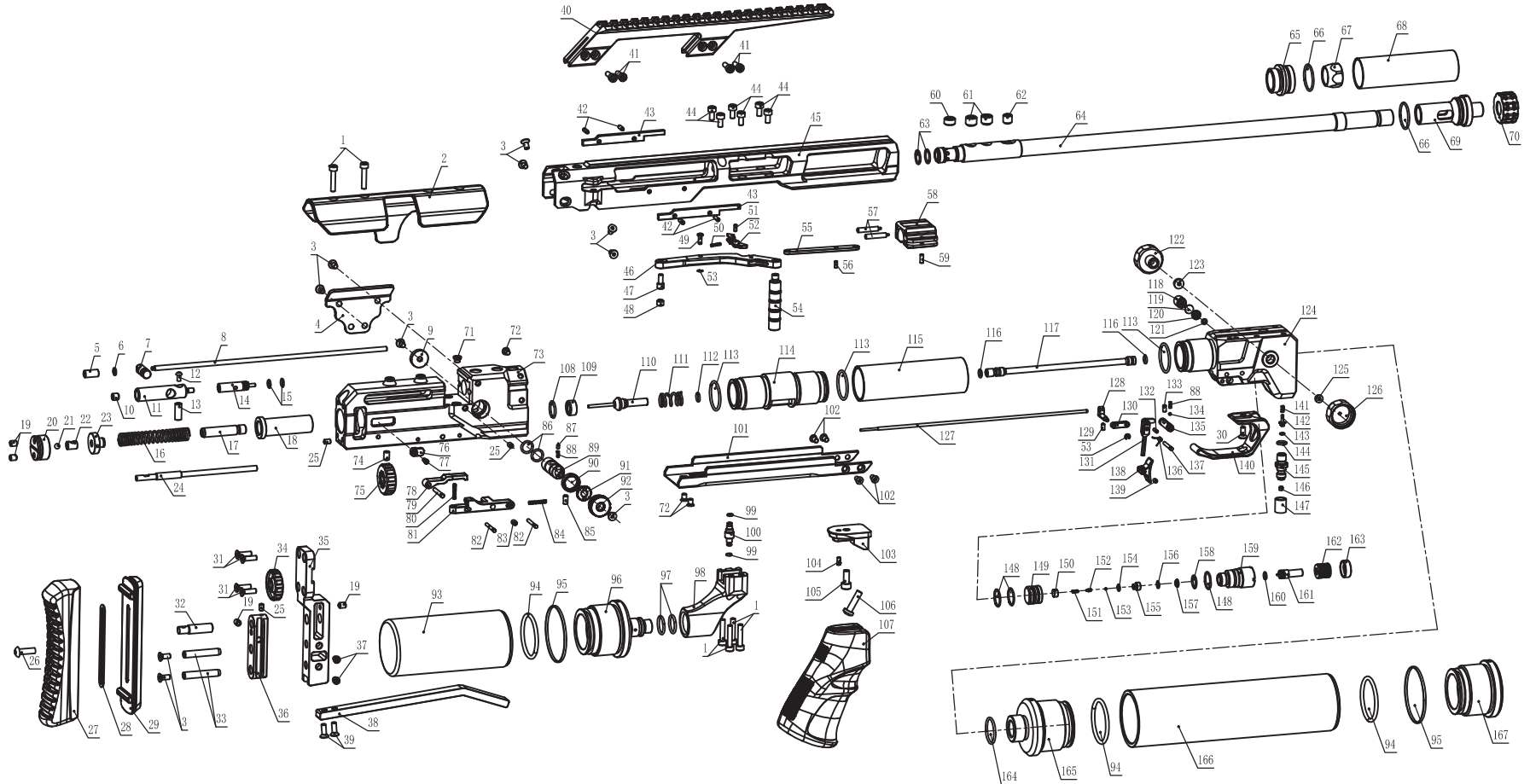

AEA Sonic Compact PARTS LIST

DIAGRAM NO.	Manufacturer Part Number	DIAGRAM NO.	Manufacturer Part Number	DIAGRAM NO.	Manufacturer Part Number	DIAGRAM NO.	Manufacturer Part Number
1	GB/T 70.1-2008-M4×20	46	2CY-3B2A(1)	91	1CY-57A(1)	136	1CY-93A(1)
2	1CY-71A(1)	47	2CY-8A(1)	92	1CY-65A(1)	137	Knurled Pin Round Head 2.5×20 45# Steel
3	GB/T 70.3-2008-M4×8	48	GB/T 77-2007-M6×5	93	1CY-27A(1)	138	1CY-89A(1)
4	1CY-53A(1)	49	2CY-3B7A(1)	94	O-Ring 36×3 NBR90	139	GB/T 77-2007-M3X4
5	2CY-6A(1)	50	2CY-3B6A(1)	95	1XD40A-E	140	1CY-28A(1)
6	GB/T 93-1987-4	51	GB/T 879.3-2000-2.5×6	96	1CY-34A(1)	141	DEF-2S-X-18-01-13
7	2CY-5A(1)	52	2CY-3B3A(1)	97	O-Ring 14×1.8 NBR90	142	HP-X-13-7.62-A-14-02
8	2CY-4A(1)	53	GB /T 896-1986-2	98	1CY-42A(1)	143	O-Ring 2.6×1.2 CPU90
9	1CY-59A(1)	54	2CY-3B4A(1)	99	O-Ring 2.5×1.5 NBR90	144	O-Ring 6.5×1.5 HNBR90
10	GB/T 77-2007-M6×6	55	2CY-3B1A(1)	100	1SA38A	145	1MCAR1B17A
11	1CY-5A(1)	56	GB/T 119.2-2000-2.5m6×6	101	1CY-45A(1)	146	1MCAR1B19A
12	GB/T 70.2-2008-M3×6	57	Spring Plunger M4×20×3×1.6	102	Hex Socket Countersunk Screw M4×8	147	1CY-60A(1)
13	1CY-62A(1)	58	2CY-7A(1)	103	1CY-25A(1)	148	O-Ring 14×1.2 HNBR90
14	1CY-4A(1)	59	GB/T 119.2-2000-3h8×8	104	Knurled Pin Flat Head 3×7 SUS 304	149	1MCAR-17B1B1A(2)
15	O-Ring 5.6×1.2 NBR90	60	Hex Socket Set Screw (Fine Thread) M10×1×6	105	GB/T 70.1-2008-M5×12	150	1MCAR-17B1B5A(2)
16	2CY-16A(1)	61	GB/T 77-2007-M10×8	106	Hex Socket Pan Head Screw M5×20	151	1MCAR-17B1B6A(2)
17	1CY-44A(1)	62	GB/T 77-2007-M8×8	107	1DN52B	152	1MCAR-17B1B5A(1)
18	1CY-63A(1)	63	O-Ring 11×1.2 NBR90	108	O-Ring 13×1.5 NBR90	153	GB/T 308.2-2010
19	Ball Set Screw M5×6	64	1CY-19A(1)	109	2CY-17A(1)	154	O-Ring 4.2×1.2 NBR90
20	1CY-41A(1)	65	1CY-39A(1)	110	1CY-87A(1)	155	1MCAR-17B1B4A(2)
21	GB/T308.1-2013	66	O-Ring 22×1.5 NBR90	111	1CY-69A(1)	156	O-Ring 5×1 HNBR90
22	1CY-11A(1)	67	1CY-23A(1)	112	O-Ring 5.8×1.5 CPU90	157	1MCAR-17B1B3A(1)
23	1CY-20A(1)	68	1CY-30A(1)	113	O-Ring 24×1.8 NBR90	158	O-Ring 10×1.2 HNBR90
24	1CY-10A(1)	69	1CY-40A(1)	114	1CY-24A(1)	159	1MCAR-17B1B2A(2)
25	GB/T 77-2007-M4×6	70	1CY-64A(1)	115	1CY-31A(1)	160	O-Ring 5×1.2 HNBR90+P
26	GB/T 70.2-2008-M5×16	71	Slotted Ball Plunger M5×5	116	O-Ring 5×1.5 NBR90	161	1MCAR-17B1B4A(1)
27	ELE-X-20-11.6-G-28-03-02	72	Hex Socket Countersunk Screw M4×6	117	1CY-35A(1)	162	GB/T 1972-2005 12.5×6.2×0.7×1-C1
28	ELE-X-20-11.6-G-28-04	73	2CY-2A(1)	118	1XD13B8A-E	163	1MCAR-17B1B3A(2)
29	ELE-X-20-11.6-G-28-03-01	74	GB/T 77-2007-M5×8	119	1XD13B7A-E	164	O-Ring 21.2×1.8 HNBR90+P
30	GB/T 70.3-2008-M4×10	75	1CY-8A(1)	120	1XD13B6A-E	165	1CY-33A(1)
31	Hex Socket Countersunk Screw M4×14	76	1CY-21A(1)	121	O-Ring 3×1.2 NBR90	166	1CY-29A(1)
32	1CY-26B3A(1)	77	1CY-22A(1)	122	1XD33B2A-E	167	1XD32A-E
33	GB/T 120.2-2000-6m6×35-B	78	1CY-61A(1)	123	1XD33B3A-E		
34	1CY-26B5A(1)	79	Knurled Pin Round Head 3×22 45# Steel	124	1CY-3A(1)		
35	1CY-26B1A(1)	80	1CY-17A(1)	125	CH-BBP-30-12.7-31-03		
36	1CY-26B2A(1)	81	1CY-55A(1)	126	CH-BBP-30-12.7-31-02		
37	POM Plunger M6×4	82	Knurled Pin Round Head 2.5×22 45# Steel	127	1CY-9A(1)		
38	1CY-26B6A(1)	83	GB/T 80-2007-M4×6	128	1CY-14A(1)		
39	GB/T 70.3-2008-M4×12	84	1CY-92A(1)	129	GB/T 80-2007-M3X6		
40	1CY-32A(1)	85	GB/T 77-2007-M4×8	130	1CY-13A(1)		
41	GB/T 70.1-2008-M4×12	86	O-Ring 9×1.5 NBR90	131	1CY-12A(1)		
42	GB/T 79-2007-M3×10	87	1CY-49A(1)	132	GB/T 879.3-2000-2.5X8		
43	2CY-9A(1)	88	1SA3B11A-D	133	GB/T 77-2007-M3X6		
44	GB/T 70.1-2008-M4×8	89	1CY-56A(1)	134	GB/T 308.1-2013		
45	2CY-1A(1)	90	1CY-51A(1)	135	1CY-15A(1)		

Exploded Diagram

AEA Sonic Compact DIAGRAM

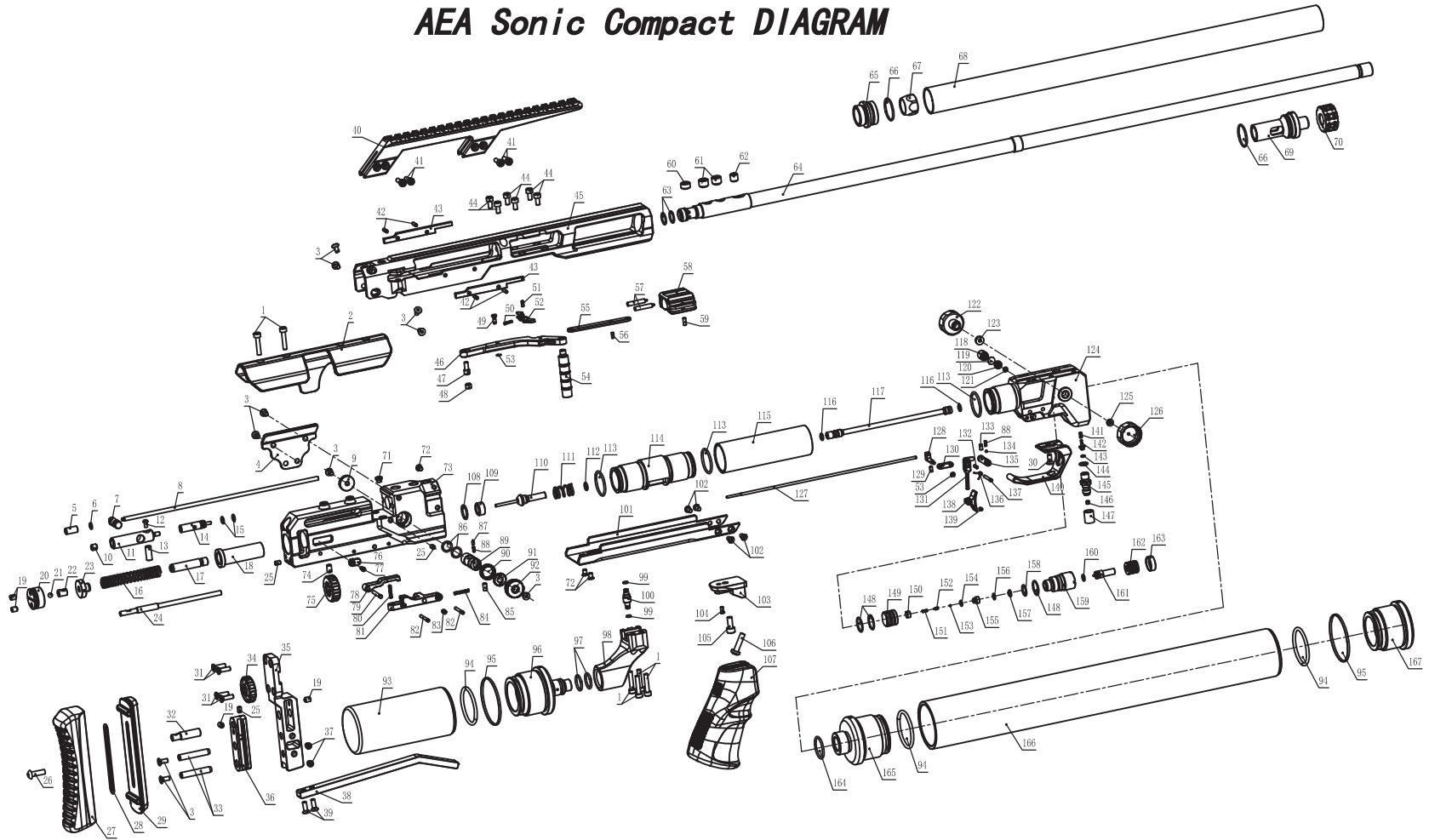

AEA Sonic Sniper PARTS LIST

DIAGRAM NO.	Manufacturer Part Number	DIAGRAM NO.	Manufacturer Part Number	DIAGRAM NO.	Manufacturer Part Number	DIAGRAM NO.	Manufacturer Part Number
1	GB/T 70. 1-2008-M4×20	46	2CY-3B2A (1)	91	1CY-57A (1)	136	1CY-93A (1)
2	1CY-71A (1)	47	2CY-8A (1)	92	1CY-65A (1)	137	Knurled Pin Round Head 2.5×20 45# Steel
3	GB/T 70. 3-2008-M4×8	48	GB/T 77-2007-M6×5	93	1CY-27A (1)	138	1CY-89A (1)
4	1CY-53A (1)	49	2CY-3B7A (1)	94	O-Ring 36×3 NBR90	139	GB/T 77-2007-M3X4
5	2CY-6A (1)	50	2CY-3B6A (1)	95	1XD40A-E	140	1CY-28A (1)
6	GB/T 93-1987-4	51	GB/T 879. 3-2000-2. 5×6	96	1CY-34A (1)	141	DEF-2S-X-18-01-13
7	2CY-5A (1)	52	2CY-3B3A (1)	97	O-Ring 14×1.8 NBR90	142	HP-X-13-7. 62-A-14-02
8	2CY-4A (1)	53	GB /T 896-1986-2	98	1CY-42A (1)	143	O-Ring 2. 6×1. 2 CPU90
9	1CY-59A (1)	54	2CY-3B4A (1)	99	O-Ring 2. 5×1. 5 NBR90	144	O-Ring 6. 5×1. 5 HNBR90
10	GB/T 77-2007-M6×6	55	2CY-3B1A (1)	100	1SA38A	145	1MCAR1B17A
11	1CY-5A (1)	56	GB/T 119. 2-2000-2. 5m6×6	101	1CY-45A (1)	146	1MCAR1B19A
12	GB/T 70. 2-2008-M3×6	57	Spring Plunger M4×20×3×1. 6	102	Hex Socket Countersunk Screw M4×8	147	1CY-60A (1)
13	1CY-62A (1)	58	2CY-7A (1)	103	1CY-25A (1)	148	O-Ring 14×1. 2 HNBR90
14	1CY-4A (1)	59	GB/T 119. 2-2000-3h8×8	104	Knurled Pin Flat Head 3×7 SUS 304	149	1MCAR-17B1B1A (2)
15	O-Ring 5. 6×1. 2 NBR90	60	Hex Socket Set Screw (Fine Thread) M10×1×6	105	GB/T 70. 1-2008-M5×12	150	1MCAR-17B1B5A (2)
16	2CY-16A (1)	61	GB/T 77-2007-M10×8	106	Hex Socket Pan Head Screw M5×20	151	1MCAR-17B1B6A (2)
17	1CY-44A (1)	62	GB/T 77-2007-M8×8	107	1DN52B	152	1MCAR-17B1B5A (1)
18	1CY-63A (1)	63	O-Ring 11×1. 2 NBR90	108	O-Ring 13×1. 5 NBR90	153	GB/T 308. 2-2010
19	Ball Set Screw M5×6	64	1CY-81A (1)	109	2CY-10A (1)	154	O-Ring 4. 2×1. 2 NBR90
20	1CY-41A (1)	65	1CY-39A (1)	110	2CY-12A (1)	155	1MCAR-17B1B4A (2)
21	GB/T308. 1-2013	66	O-Ring 22×1. 5 NBR90	111	1CY-69A (1)	156	O-Ring 5×1 HNBR90
22	1CY-11A (1)	67	1CY-23A (1)	112	O-Ring 5. 8×1. 5 CPU90	157	1MCAR-17B1B3A (1)
23	1CY-20A (1)	68	1CY-48A (1)	113	O-Ring 24×1. 8 NBR90	158	O-Ring 10×1. 2 HNBR90
24	1CY-10A (1)	69	1CY-40A (1)	114	1CY-24A (1)	159	1MCAR-17B1B2A (2)
25	GB/T 77-2007-M4×6	70	1CY-64A (1)	115	1CY-31A (1)	160	O-Ring 5×1. 2 HNBR90+P
26	GB/T 70. 2-2008-M5×16	71	Slotted Ball Plunger M5×5	116	O-Ring 5×1. 5 NBR90	161	1MCAR-17B1B4A (1)
27	ELE-X-20-11. 6-G-28-03-02	72	Hex Socket Countersunk Screw M4×6	117	1CY-35A (1)	162	GB/T 1972-2005 12. 5×6. 2×0. 7×1-C1
28	ELE-X-20-11. 6-G-28-04	73	2CY-2A (1)	118	1XD13B8A-E	163	1MCAR-17B1B3A (2)
29	ELE-X-20-11. 6-G-28-03-01	74	GB/T 77-2007-M5×8	119	1XD13B7A-E	164	O-Ring 21. 2×1. 8 HNBR90+P
30	GB/T 70. 3-2008-M4×10	75	1CY-8A (1)	120	1XD13B6A-E	165	1CY-33A (1)
31	Hex Socket Countersunk Screw M4×14	76	1CY-21A (1)	121	O-Ring 3×1. 2 NBR90	166	1CY-86A (1)
32	1CY-26B3A (1)	77	1CY-22A (1)	122	1XD33B2A-E	167	1XD32A-E
33	GB/T 120. 2-2000-6m6×35-B	78	1CY-61A (1)	123	1XD33B3A-E		
34	1CY-26B5A (1)	79	Knurled Pin Round Head 3×22 45# Steel	124	1CY-3A (1)		
35	1CY-26B1A (1)	80	1CY-17A (1)	125	CH-BBP-30-12. 7-31-03		
36	1CY-26B2A (1)	81	1CY-55A (1)	126	CH-BBP-30-12. 7-31-02		
37	POM Plunger M6×4	82	Knurled Pin Round Head 2. 5×22 45# Steel	127	1CY-9A (1)		
38	1CY-26B6A (1)	83	GB/T 80-2007-M4×6	128	1CY-14A (1)		
39	GB/T 70. 3-2008-M4×12	84	1CY-92A (1)	129	GB/T 80-2007-M3X6		
40	1CY-32A (1)	85	GB/T 77-2007-M4×8	130	1CY-13A (1)		
41	GB/T 70. 1-2008-M4×12	86	O-Ring 9×1. 5 NBR90	131	1CY-12A (1)		
42	GB/T 79-2007-M3×10	87	1CY-49A (1)	132	GB/T 879. 3-2000-2. 5X8		
43	2CY-9A (1)	88	1SA3B11A-D	133	GB/T 77-2007-M3X6		
44	GB/T 70. 1-2008-M4×8	89	1CY-56A (1)	134	GB/T 308. 1-2013		
45	2CY-1A (1)	90	1CY-51A (1)	135	1CY-15A (1)		

SPECIFICATION



Caliber (mm)	5.5 mm / 6.35 mm / 7.62 mm
Barrel Length (mm)	441 mm
Total Length (mm)	647 mm
Weight(g)	3.88 kg
Air Tube Capacity (cc)	350 CC
Max Air Filling Pressure	48 MPa / 7000 psi
Magazine Capacity	12 / 10 / 9
Scope Attachment	20MOA Picatinny



Caliber (mm)	5.5 mm / 6.35 mm / 7.62 mm
Barrel Length (mm)	800 mm
Total Length (mm)	1006 mm
Weight (g)	4.75 kg
Air Tube Capacity (cc)	625 CC
Max Air Filling Pressure	48 MPa / 7000 psi
Magazine Capacity	12 / 10 / 9
Scope Attachment	20MOA Picatinny

Air Filling Procedure

1. Pull the bolt rearward and insert the magazine.

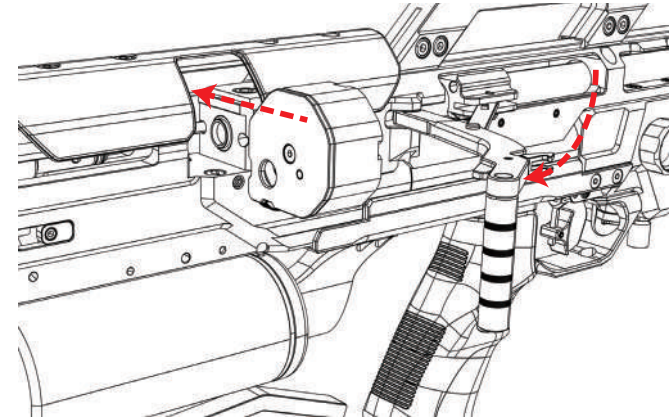

- 2.1 Hammer spring tension adjustment wheel and tension scale indicator block

- 2.2 Butt pad adjustment: fore/aft and vertical adjustment

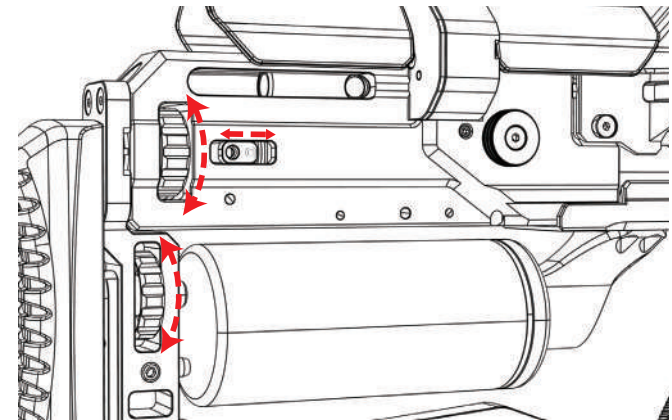

Close the bleed screw on your air source.

Begin filling slowly to allow internal seals to equalize.

If air escapes from the barrel during initial filling: Cock the rifle once. This releases hammer pressure from the valve and allows the system to pressurize normally.

Monitor the filling gauge on your air source.

When complete, stop airflow, open the bleed valve fully, and disconnect the hose only after pressure is released.

Hand Pump Notes

- Drain moisture traps regularly.
- Avoid rapid, continuous pumping to reduce heat and wear.
- Always use a pump designed for **7000 PSI** PCP filling.

Rear Airtube

3.1 Airflow Adjustment Knob

- ① Pull the adjustment knob outward
- ② Rotate to the desired position
- ③ Push the knob inward to lock

Warning: The knob must be fully pushed in and locked. Failure to do so may result in gas discharge during firing, posing a risk of injury.

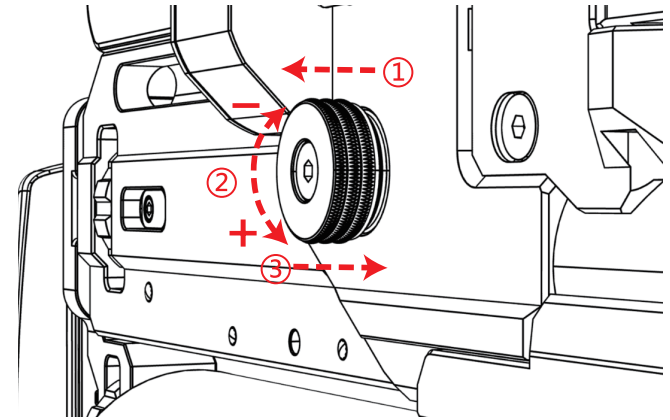

4. Filling

Use an 8 mm female quick-connect fitting for charging.

Only use clean, dry, oil-free compressed air.

Maximum fill pressure: 48 MPa / 7000 psi.

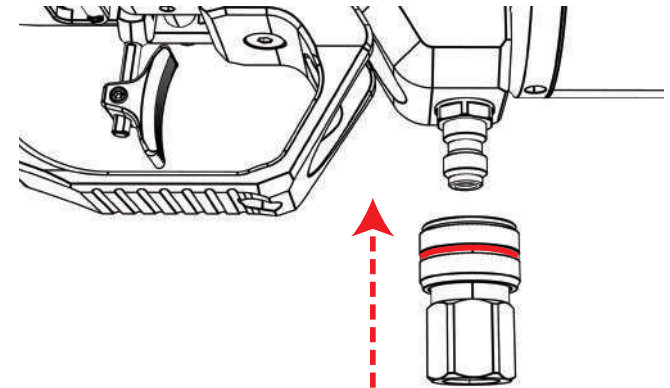

LOADING, COCKING & FIRING

Safety Before Loading

- Ensure muzzle is pointed in a safe direction.
- Move the safety to the SAFE position.
- Never load the rifle with the safety off.

Cocking the Rifle

5.1 Safety Valve

When the regulator plenum pressure reaches or exceeds **36 MPa**, the safety valve will activate and release pressure.

The safety valve disc must be replaced before further use.

5.2 Safety (Manual Safety)

Push the safety to the right.

When the red indicator ring is visible, the firearm is in the ready-to-fire condition.

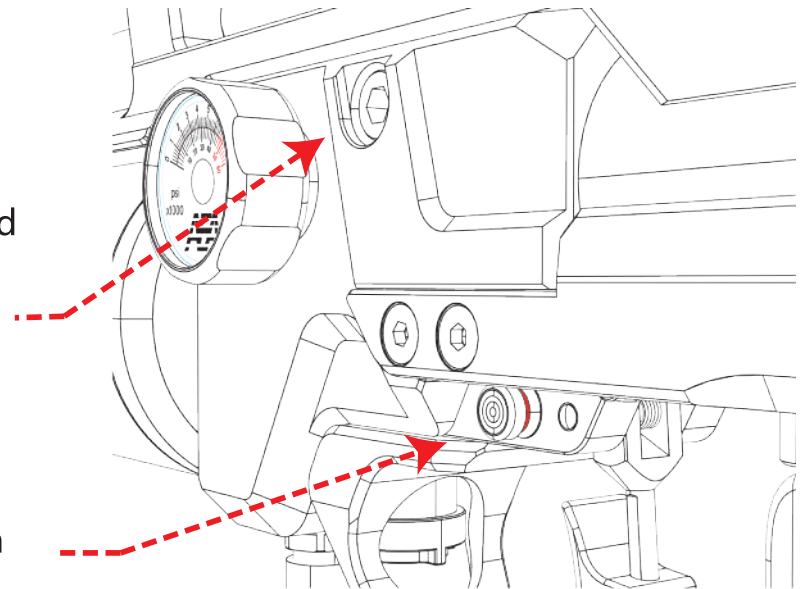

6. Charging Handle Safety

The charging handle safety must be depressed before the handle can be pulled rearward.

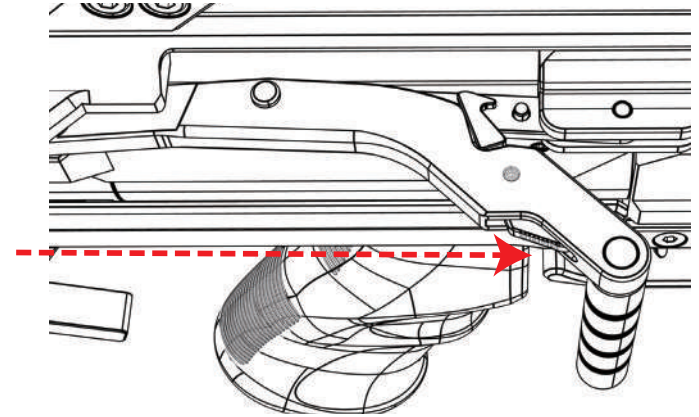

Loading the pellets and slugs

7. Regulator (Pressure Regulator Valve)

Adjustment range: 5–30 MPa

Use the dedicated adjustment tool:

- Rotate clockwise to increase pressure
- Rotate counterclockwise to decrease pressure

Warning: Do not fully unscrew the adjustment nut, as this may damage the regulator.

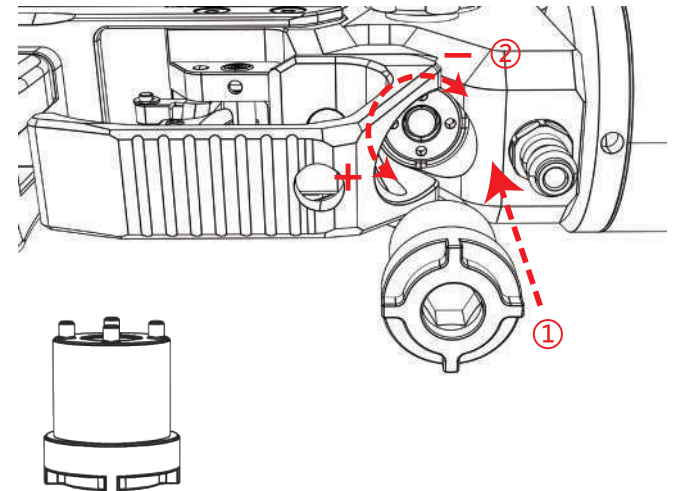

8. Side Lever Operation

Disengage the charging handle safety and pull the side lever rearward to cock the mechanism.

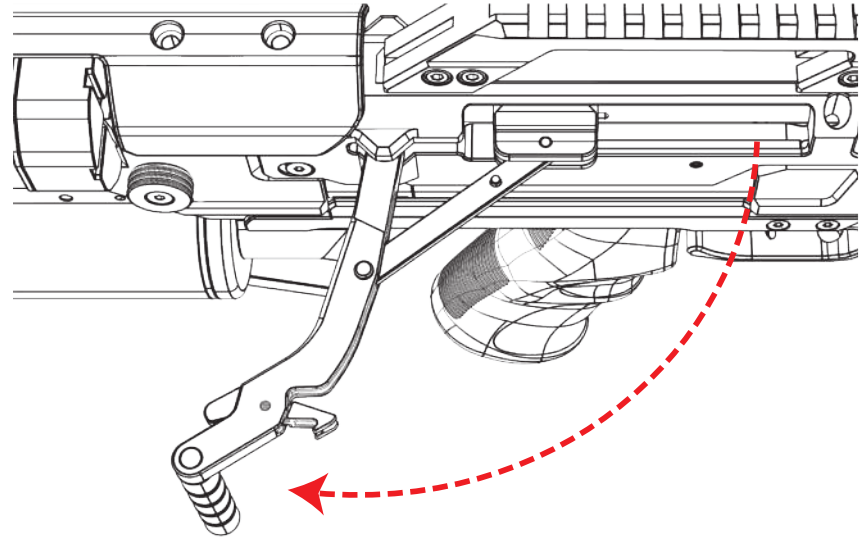

Firing

- Point the rifle in a safe direction.
- Move the safety to FIRE only when prepared to shoot.
- Maintain proper trigger discipline at all times.

HAMMER DE-COCKING

To safely de-cock the rifle:

Pull and hold the side-lever fully to the rear.

While holding the lever, gently squeeze the trigger.

Allow the hammer spring to decompress under full control.

Return the side-lever to the forward position.

WARNING



Never release the lever unexpectedly during de-cocking.

After de-cocking, dry-fire into a safe direction to confirm the chamber is clear.

CLEANING & MAINTENANCE

Exterior Cleaning

- Wipe the exterior with a soft cloth.
- Apply a light coat of high-quality gun oil to protect metal surfaces.

Barrel Care

Use only airgun-appropriate tools:

- Cleaning pellets
- One-piece cleaning rod
- Non-metallic or airgun-safe brushes

Do NOT use:

- Water
- Firearm solvents
- Degreasers or chemical cleaners
- Steel brushes or jointed rods

Liquid solvents may damage seals, coatings, valve components, and O-rings.

Inspection

- Visually inspect the air tank and seals every 3 years or if damage is suspected.
- If leaks, cracks, abnormal sounds, or irregular function occur—stop using the rifle immediately.

STORAGE



Storage Guidelines

- Unloaded
- In a dry, cool, dark environment
- With pellets/slugs kept separately
- Out of reach of children

The rifle may be stored pressurized unless local regulations require otherwise.

Avoid Environmental Stress

- Do not expose the rifle to direct sunlight or prolonged heat.
- Avoid high humidity to prevent internal or external corrosion.
- Temperatures above normal may degrade seals.

Long-Term Storage

- Apply protective oil to exposed metal.
- Use a gun safe or case with humidity control.
- If stored longer than 6 months, visually inspect all components before use.

OPERATIONAL NOTICES

- Do not modify or remove any safety components.
- Do not attempt to access or adjust the factory-calibrated valve system.
- Only use dry, filtered compressed air.
- Never exceed the maximum fill pressure.
- Always follow local shooting laws and safe-handling practices.

Unauthorized disassembly, power tuning, or internal modification voids the warranty.

WARRANTY — ONE-YEAR LIMITED WARRANTY Coverage

AEA airguns are warranted to the original purchaser against defects in materials and workmanship for one (1) year from the date of purchase.
Proof of purchase is required.

Exclusions

Warranty does not cover:

- Normal wear items (O-rings, seals, magazines, external finish)
- Damage from misuse, abuse, neglect, or accidents
- Damage from unauthorized repair, modification, or disassembly
- Damage from overfilling or using non-air gases
- Cosmetic wear that does not affect function

Void Conditions

Warranty is void if the rifle has been:

- Modified or tuned
- Opened or repaired by unauthorized personnel
- Used with non-approved components, gases, or ammunition

How to Obtain Service

Contact your authorized dealer or seller.

Provide proof of purchase, serial number, photos, and a description of the issue.

Follow shipping or inspection instructions from the dealer or service center.

Do not ship the product without prior authorization.

Manufacturer' s Rights

AEA Precision Airguns reserves the right to:

- **Modify or improve products without prior notice**
- **Change specifications or discontinue components**
- **Determine whether a repair or replacement is appropriate**

**AEA PRECISION AIRGUNS INC
ALL RIGHTS RESERVED**

Various AEA Airguns Bring You Completely Different Experiences

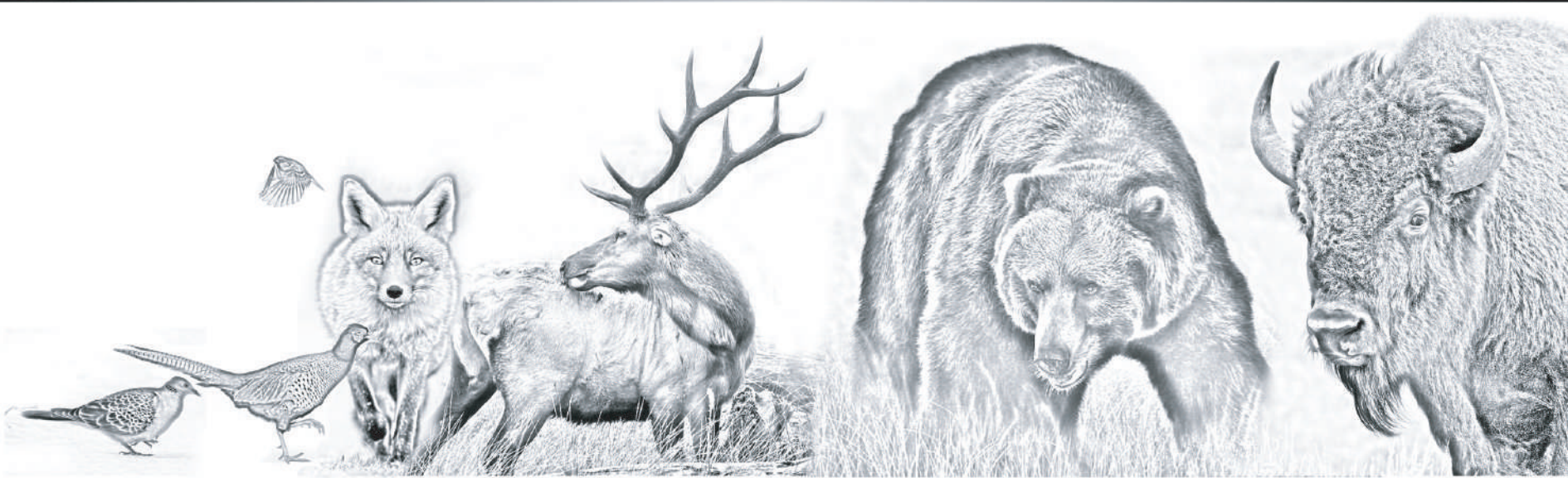

AEA
PRECISION AIRGUNS

AEA PRECISION AIRGUNS INC.

www.aeaairgun.com

aeaairgun@gmail.com