

Assembly and Usage  
Instructions for the...



# STABLE TABLE<sup>®</sup>

## SHOOTING BENCH



Instruction  
#1000196

Revision: E

**STOP!**

If you have a problem with this product, **DON'T RETURN IT TO THE STORE WHERE YOU PURCHASED IT.** Contact customer service at...

**Battenfeld**  
Technologies, Inc.

5885 West Van Horn Tavern Road / Columbia, MO 65203  
573-445-9200 / Email: [sales@battenfeldtechnologies.com](mailto:sales@battenfeldtechnologies.com)  
Or visit our website @ [www.battenfeldtechnologies.com](http://www.battenfeldtechnologies.com)

**NOT WARRANTED AGAINST MISUSE, ABUSE, OR COMMERCIAL USE.**

Limited Warranty

Every Caldwell product is warranted to be free of defects in materials and workmanship for a period of one (1) year from the date of original purchase. Caldwell will, at its option, repair or replace without charge, except for transportation costs, parts that fail under normal use and service when operated and maintained in accordance with our Instructions. This warranty does not apply to normal wear or to items whose life is dependent upon their use and care. This warranty is in lieu of all other warranties, expressed or implied and releases Caldwell, its affiliates, and its vendors from all other obligations and liabilities.

**ATTENTION CUSTOMERS**

Battenfeld constantly seeks to improve our products. As a result of these efforts, your package may include components that vary slightly in appearance from product photos on packaging or instructions.

## Safety Precautions

- Leaning rearward on bench may cause tipping
- Always be aware of surroundings when rotating the bench
- Never sit or stand on the table top
- Never lean a firearm against the bench as it may spin
- Never use your bench on sloped terrain

## Identifying all the components of your Stable Table

Thank you for purchasing a Caldwell Stable Table. Please take a moment to locate all of the parts shown in this photo.

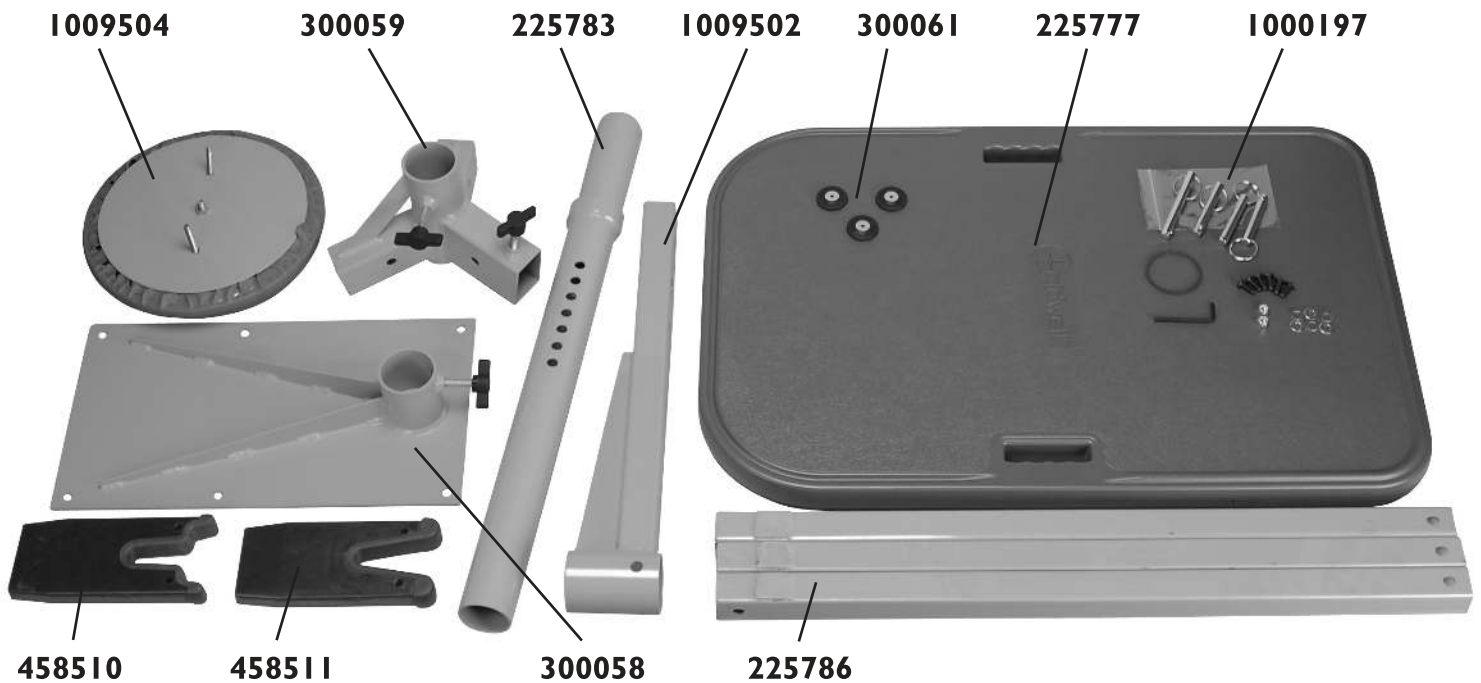

Qty	Description	Part #
1	Table Top	225777
1	Table Mounting Bracket with Knob	300058
1	Center Support Tube	225783
1	Central Hub with Knobs	300059
3	Legs	225786
1	Seat Support Arm	1009502
1	Padded Seat Cushion with Steel Plate	1009504
3	Rubber Feet	300061
2	Gun Cleaning Forks (Right, Left)	458510, 458511

Qty	Description	Part #
<b>1</b>	<b>Hardware Pack Including:</b>	<b>1000197</b>
2	5/16" Nylon-Locking Nuts	540769
6	5/16" x 3/4" Long Cap Screws	170475
8	5/16" Washers	473465
1	Nylon Bearing	225784
1	3 1/2" Long Quick Release Pin	300055
3	2 1/2" Long Quick Release Pins	300054
1	3/16" Allen Wrench	253194

# Putting Your Stable Table Together

Now that you have identified all of your parts, you can begin assembling your Stable Table. In just a few easy steps your Stable Table will be assembled and ready to enjoy. You will need the included 3/16" Allen wrench and a 1/2" wrench (not included) to assemble the bench.

1. First, insert a Leg into the large, rectangular socket on the Hub. Ensuring that the square Steel Pad is positioned toward the threaded hole (**See Photo B**), push one of the shorter, 2 1/2" long pins through the socket to secure the Leg. (You may need to unscrew the leg adjustment knob to do this.)

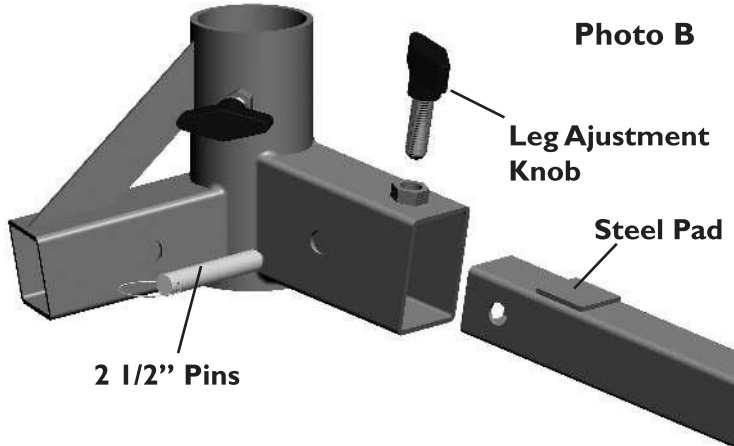

2. Next, insert the remaining two legs in the smaller square sockets. For these legs, the square steel pad should be on the opposite end from the Hub. Use the other two 2 1/2" long pins to secure these Legs.

3. With the Legs now fully assembled, turn the large knob in the leg socket until it contacts the steel pad on the Leg, and continue to tighten it until the Hub sits parallel with the ground. This knob is used to level the bench on uneven terrain. Lifting up on the bench will make turning the knob easier.

4. Next, place the nylon bearing over the Center Support Tube so that it is flat against the collar on the short side of the tube. (**See Photo C**)

5. Back the center support tube locking knob out so the tube itself will not hang up on the screw upon insertion. With the bearing in place, insert the Center Support Tube into the Hub so that the bearing and collar are sitting against the top of the Hub.

6. The next step is to attach the Seat to the Seat Arm. Your seat comes with a steel plate already attached. This plate has two 5/16" bolts protruding from the bottom. Align these bolts with the two smaller holes in the Seat Arm, and use the 5/16" Nylon Nuts and washers to fasten them. (You will need a 1/2" wrench for this)

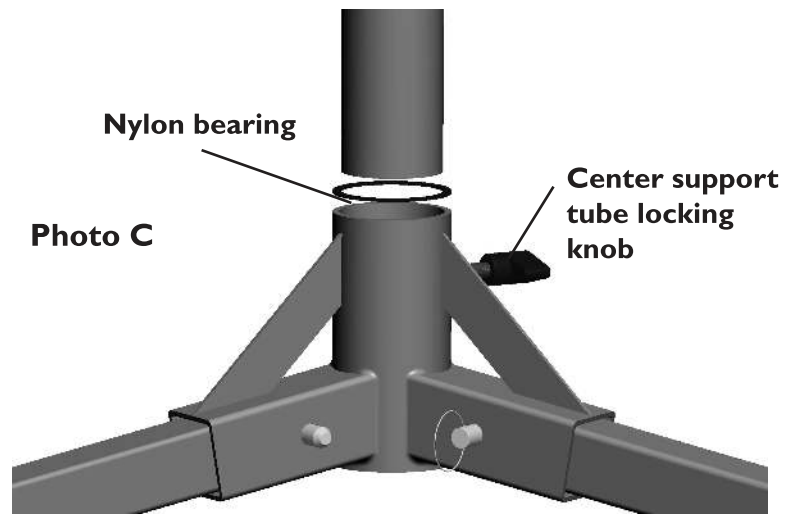

7. With the Seat now assembled to the Seat Arm, slide the Seat Arm over the top of the Center Support and attach it with the longer, 3 1/2" quick release pin. (You will notice that your Center Support has 7 holes in it. These holes allow you to customize your seat height so that you may achieve the most comfortable shooting position possible.)

8. The next step is to attach the Table Top to the Table Mounting Bracket. This is done with the six, 3/4" long screws and washers that are left. With the Table Top and Bracket oriented as shown (See Photo D), put the washer over the screw and slide the screw through from the bottom of the Table Bracket into the threaded insert in the table. Repeat for all 6 screws, using the 3/16" Allen wrench to tighten them.

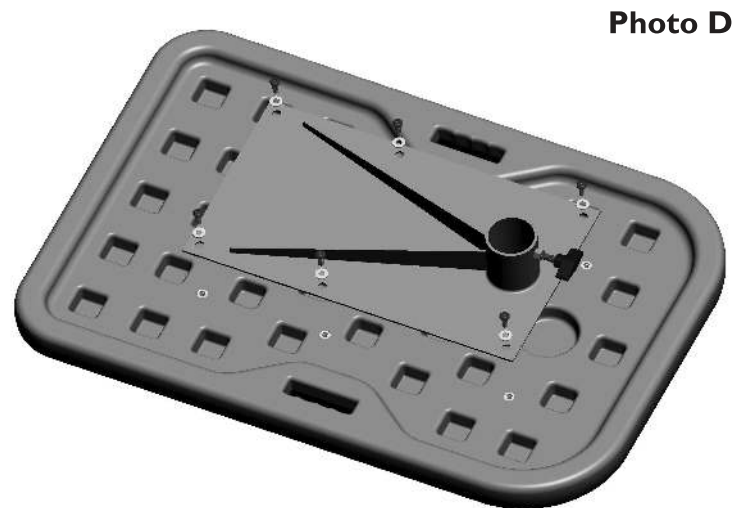

9. Finally, slide the now-assembled Table Bracket onto the top of the Center Support Tube. It should spin freely. The knob on the table bracket can be used to lock the table from rotating.

**Congratulations, your Caldwell Stable Table is now fully assembled!**

## Using Your Stable Table 4.

Your Caldwell Stable Table is loaded with features to make your shooting as accurate as possible.

### Adjustable Leg:

With your Stable Table's adjustable leg, you can have a perfectly level shooting platform almost anywhere. When setting up your Stable Table, simply position the adjustable leg to either the high or low side of the terrain, and turn the large knob to adjust it accordingly until the table top is level. Lifting the bench slightly will make the knob easier to turn. **Never adjust the bench while sitting on it, as the stress can deform the threads on your knob. Level the bench BEFORE placing firearms or other objects on the Table Top.**

### 360° Rotation:

The bench will spin 360° about the hub. The nylon bearing will allow your bench to spin freely, and the threaded knob located on the upper portion of the Hub will lock it into place so that your bench is ultrasteady when you fire. If you prefer that your bench spin with even less effort, you may use a small amount of grease on the inside of the hub. The Table Top also spins 360° independently of the bench, allowing you to set your bench up exactly the way you want it. While sitting on the bench, turn the top so that it's positioned to align you perfectly with your gun. Now tighten the threaded knob on the table bracket and it's firmly locked into place.

### Handles and Cleaning Forks:

Another innovative feature is the handles in your Table Top. Your top is equipped with two molded-in handles so that you can easily transport your bench, but these handles also allow you to easily clean your firearm after a fun day of shooting. The included Gun Cleaning Forks will slide into these handles, giving you a sturdy and convenient cleaning platform.

### BR FEET (Rubber Feet):

One other feature added to your Stable Table are the rubber feet. These are the three rubber pads included with your bench. **(1)** These feet allow you to safely use shooting rests with spiked feet without damaging your table top. Simply place the rubber pads under your rest's spiked feet to protect your bench. **(2)** You can then shoot with confidence that your shooting rest will not slip or damage the table top.

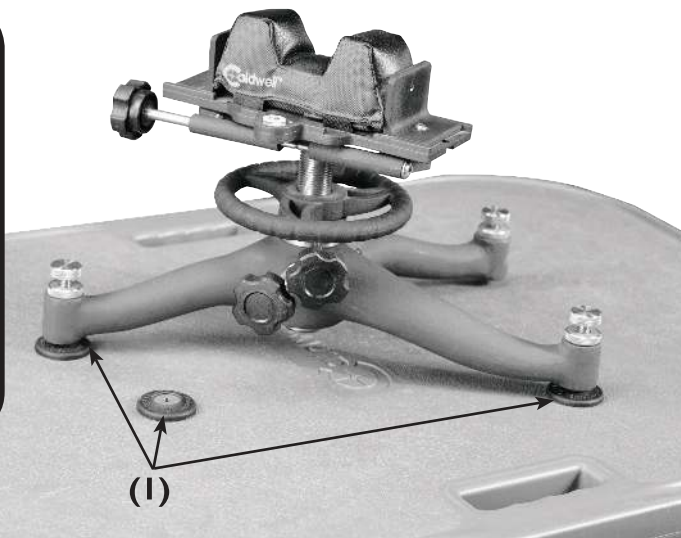
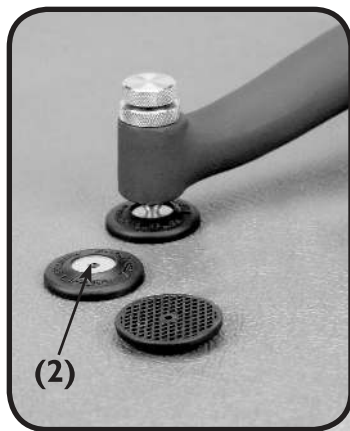

(440907-Rock-BR Shooting rest with spiked feet NOT INCLUDED)



Always try to position the seat over one of the legs for maximum stability. Don't lean back when sitting on the bench. Leaning back could change the balance of the bench and cause it to tip. Avoid bouncing or sitting down heavily onto the bench, as it may cause damage to the bench.

**ALWAYS FOLLOW FIREARM SAFETY GUIDELINES**

**Battenfeld**  
Technologies, Inc.

5885 West Van Horn Tavern Road / Columbia, MO 65203  
573-445-9200 / Email: [sales@battenfeldtechnologies.com](mailto:sales@battenfeldtechnologies.com)