

BASIC SAFETY RULES

1. Always treat your airgun as if it is loaded, even if you know it is unloaded.
2. Never point your airgun at anyone or allow anyone to point an airgun at you, even if you know it is not loaded.
3. Always carry your airgun so the direction of the muzzle is under control, even if you stumble.
4. Always keep your finger off the trigger unless you are ready to shoot.
5. Always be sure of your target and what lies behind it before firing your airgun. Know what you will hit if you miss your target.
6. Never leave a loaded airgun unattended.
7. Beware of targets that may cause ricochets.
8. Everyone in the vicinity should wear safety glasses when an airgun is being used, shot or loaded.

Illustrations and photographs are for information purposes only
and may not show the exact model purchased.

IZH 46M air pistol owner's manual



5135 Naiman Parkway
Solon, OH 44139
216-220-1180



5135 Naiman Parkway
Solon, OH 44139
216-220-1180

Record the serial
number of your airgun.....



Follow the warnings and safety procedures shown here and throughout this manual.

Not a toy. Adult supervision required. This airgun is intended for use by those 18 years of age or older. Misuse or careless use may cause serious injury or death. May be dangerous up to 500 yards.

Do not use this airgun until you have read and understood this owner's manual.

Do not inhale dust from lead pellets or put lead pellets in the mouth. Wash hands after handling lead. Lead pellets contain lead, a chemical known to the State of California to cause cancer and birth defects (or other reproductive harm).

Use the correct pellet size for your airgun. Never reuse pellets. The use of any other kind of ammunition can cause injury to you or damage to your airgun.

Keep your finger off the trigger while cocking your airgun. When you are sure of your target and backstop and the area around the target is clear, you may take your airgun off SAFE and squeeze the trigger to fire. Always keep your airgun on SAFE until you're ready to shoot.

Remember to place your target carefully and THINK about what you will hit if you miss the target.

Do not assume your airgun is unloaded if it fails to fire properly!

Never leave your airgun loaded. Always treat an airgun as if it is loaded, even if you think it is not. Always transport your airgun unloaded and in a hard case.

Never point an airgun at another person or in an unsafe direction.

This airgun does not have a safety. YOU are the ultimate safety for your gun.

You and others with you should always wear safety glasses to protect your eyes.

Do not shoot at hard surfaces or at the surface of water. The pellet may bounce or ricochet and hit someone or something you did not intend to hit.

Always choose your target carefully. It is best to shoot at paper targets attached to a safe backstop or a trap intended to safely stop and/or capture airgun ammunition. Your backstop should be checked for wear before and after use. Replace your backstop if the surface is worn or damaged or if a ricochet occurs.

Do not disassemble, tamper with or attempt to repair or modify your airgun. Doing so may void your warranty and may result in injury. Contact Air Venturi at 216-220-1180 for repair.

In the unlikely event your airgun malfunctions or exhibits reduced performance, DO NOT attempt to fix the problem yourself. Call Air Venturi at 216-220-1180 so we can address any issues or have you return your airgun for repair.

Children are attracted to and can operate guns that can cause severe injuries or death. Prevent child access by always keeping guns locked away and unloaded when not in use. If you keep a loaded gun where a child obtains and improperly uses it, you may be fined or sent to prison.

Warranty

Your IZH airgun is manufactured to the highest standards, using the finest materials to give a lifetime of service. In the unlikely event there are any defects in materials or workmanship in the first twelve (12) months after retail purchase, we will repair or replace your airgun under warranty. Keep your original purchase receipt to obtain warranty repairs.

What is covered: Replacement parts and labor. Transportation charges to consumer for return of repaired product.

The warranty will be invalid if:

- The airgun has been disassembled and incorrectly reassembled.
- The airgun is found to have lubrication not recommended by Air Venturi.
- The airgun has been fitted with non-Air Venturi parts.
- The airgun has been misused or abused.
- The original purchase receipt cannot be presented.

The warranty does NOT cover:

- O-rings, screws, seals, springs or stocks.
- Any damages or faults caused by owner misuse or action.
- Shipment damage of the airgun to or from Air Venturi.
- Transportation charges to Air Venturi for defective products.
- Damages caused by abuse or failure to perform normal maintenance.
- Parts subject to normal wear and tear.
- Consequential damages, incidental damages or incidental expenses including damage to property.
- Any other expense.

Note: Some states do not allow the exclusion or limitation of incidental or consequential damages, so the above limitation or exclusion may not apply to you.

This warranty is in addition to your statutory rights. Retain your sales receipt as proof of purchase and to obtain warranty coverage.

Warranty claims for U.S. and Canadian Customers: Call Air Venturi at 216-220-1180 before returning any product.

Implied warranties: Any implied warranties, including the implied warranties of merchantability and fitness for a particular purpose, are limited in duration to one year from date of retail purchase.

Note: Some states do not allow limitations on how long an implied warranty lasts, so the above limitation may not apply to you.

To the extent any provision of this warranty is prohibited by federal, state or municipal law which cannot be preempted, it shall not be applicable. This warranty gives you specific legal rights, and you may also have other rights which vary from state to state and country to country.

Exploded parts view of IZH 46M

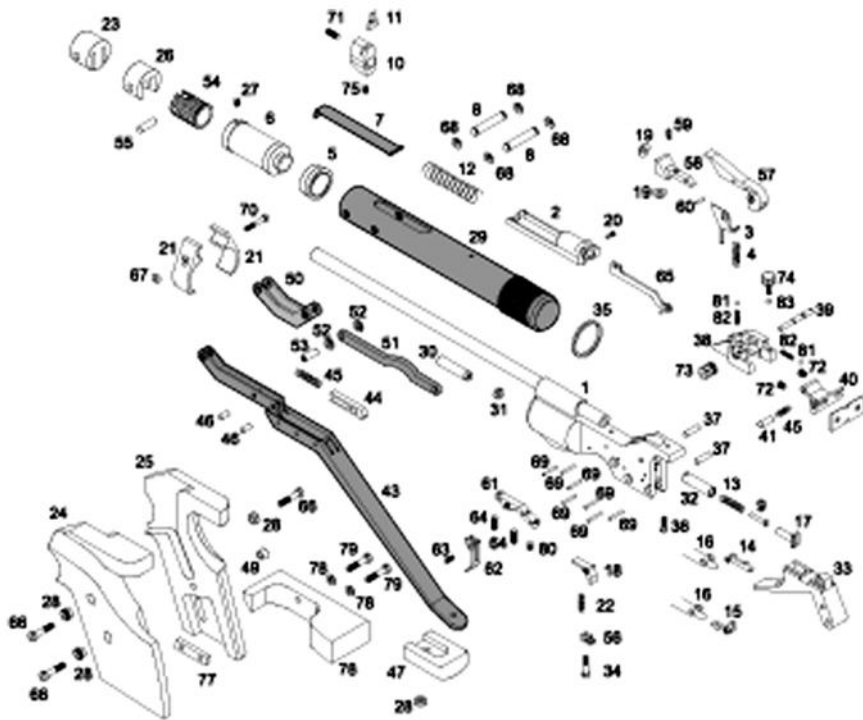

- | | | | |
|--------------------------|------------------------|--------------------|--------------------|
| 1. frame | 22. spring | 43. cocking arm | 64. screw |
| 2. slide latch | 23. plug | 44. span bar | 65. bolt bar |
| 3. blocking lever | 24. left-hand grip | 45. spring | 66. screw |
| 4. blocking lever spring | 25. right-hand grip | 46. pin | 67. nut |
| 5. pistol seal | 26. plug | 47. lever grip | 68. washer |
| 6. piston | 27. screw | 48. screw | 69. pin |
| 7. bar | 28. screw bushing | 49. washer | 70. screw |
| 8. hinge pin | 29. cylinder | 50. hinge | 71. screw |
| 9. main valve | 30. valve seat | 51. connecting rod | 72. screw |
| 10. front sight base | 31. valve seat | 52. roller | 73. sight nut |
| 11. front sight | 32. bushing | 53. pin | 74. sight screw |
| 12. slide latch spring | 33. guard | 54. heelpiece | 75. plunger spring |
| 13. valve spring | 34. screw | 55. pin | 76. palm rest |
| 14. valve sear | 35. o-ring | 56. lock | 77. grip insert |
| 15. trigger sear | 36. screw | 57. bolt lever | 78. washer |
| 16. sear spring | 37. pin | 58. bolt | 79. spring |
| 17. valve stem | 38. sight base | 59. spring | 80. screw |
| 18. trigger lever | 39. pin | 60. pin | 81. ball |
| 19. o-ring | 40. rear sight | 61. trigger base | 82. spring |
| 20. screw | 41. sight base plunger | 62. trigger | 83. washer |
| 21. yoke | 42. rear sight leaf | 63. trigger screw | |

The IZH 46M is a .177-caliber, single-stroke pneumatic air pistol. Compressed air is forced into a chamber through the full movement of the pump lever. Do not pump it more than once per shot. Pump and cock it only when you are ready to shoot. Move the pump lever fully and return it to its resting position. This air pistol is cocked in the final few degrees of pump lever movement. Read and follow these directions to safely use and maintain your airgun and to get the most enjoyment from it.

TRIGGER ADJUSTMENTS

The trigger is adjustable in several ways. As you adjust one aspect, the others will change, as well. The screw behind the trigger blade adjusts the overtravel (A). The screw behind that adjusts the location of the second stage (B). The screw in front of the trigger blade adjusts the length of the first-stage pull (C). You MUST adjust the length of the first-stage pull (C) and the location of the second stage (B)

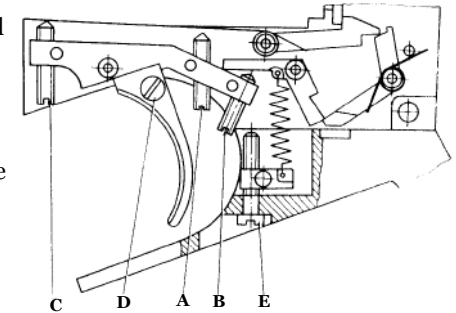

together, or you will introduce a false second-stage stop. The large screw at the top of the trigger blade allows repositioning of the blade (D). Trigger-pull weight is adjusted by the large screw at the bottom rear of the triggerguard (E). Do not adjust lighter than the ISSF-regulated 500 grams (17.6 oz.).

The pistol may be safely cocked and dry-fired for training and trigger adjustment by releasing the bolt and pulling it up until the trigger cocks. Return it as if you were firing a pellet, and the trigger will fire without air being exhausted.

GRIP

The grip should be held tight to the receiver. If you find it's loose, tighten the screw but do not over tighten it.

BARREL

The IZH 46M has a rifled steel barrel and will not normally need cleaning.

SIGHTS

The sights are metal. The front is fixed and the rear sight is fully adjustable for windage and elevation. (Photos 5 & 6)

PUMP LEVER

Below the barrel is the pump lever. Pull it down and forward until the bolt points up. If you don't pull it all the way forward, the gun will not cock and air cannot be compressed into the chamber.

BOLT

The bolt is above the grip and in front of the rear sight. It should be pointed straight up for loading and compression of the air in the cylinder. (Photo 7) The bolt lever is located behind the bolt and secures the bolt in place for firing. (Photo 8)

PUMPING & COCKING

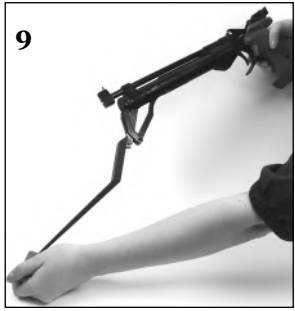

Hold the pistol grip with your dominant hand but don't touch the trigger or bolt. Point the gun in a safe direction and pull the pump lever forward (Photo 9) until the bolt assembly pops up to a 90° angle (you should hear a click as it pops up). (Don't overextend or force the pump lever to avoid damaging the airgun.) When fully extended (Photo 10), the bolt should be popped up and open. Do not pull past the click of the bolt popping up. Return the pump lever to its resting place, which compresses air for firing. (Photo 11)

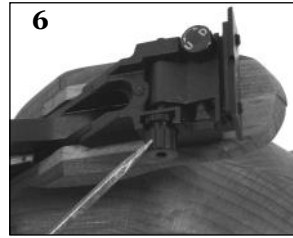
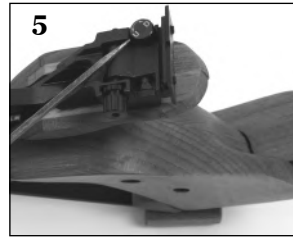

If you cocked the gun correctly and pressurized it, you will notice resistance as you bring the lever back. Keep your fingers away from the trigger and breech when pumping the gun.

LOADING

After following the above cocking sequence, insert a .177-caliber lead pellet into the breech (skirt facing the rear). Seat the pellet fully or it will be nicked and deformed when you close the bolt, and accuracy will be compromised. Press down the bolt lever to lock it (Photo 12). If you have not closed the bolt completely, the gun will not fire the pellet but it will discharge the compressed air. There is no manual safety. Leaving the bolt open until you're ready to fire is one way to assure that you do not fire the pellet before you're ready. Use only new lead pellets.

FIRING

After cocking and loading as shown above, point the airgun in a safe direction and squeeze the trigger. The pellet will discharge. To fire another pellet, follow the cocking and loading procedures. In storage, leave the bolt lever uncocked by sliding the latch on the breech forward toward the muzzle. (See above graphic)



MAINTENANCE

Before doing any maintenance on your airgun, make sure it's unloaded.

Lubricate the air compression chamber with a high-flashpoint oil designed specifically for use inside an air compression chamber. Put 3 drops of oil on the pump head, which you can see when the pistol is upside down and the pump lever is extended.

Lubricate the air compression chamber and air compression seal. Following the cocking instructions, cock the air pistol. Insert a few drops of oil into the compression chamber transfer port. Oil the airgun after every 500 shots.



Also, lightly oil the cocking arm linkage and bolt pivot points with machine oil every six months.

Do not use firearm cleaners or low-flashpoint oils in the air compression chamber or near the transfer port and breech seal to avoid damaging your airgun.

If you feel additional maintenance is required, contact Air Venturi at 216-220-1180.